

# **Series 50 XM (M1350B)**

# **Series 50 XMO (M1350C)**

# **Fetal/Maternal Monitors**

INSTRUCTIONS FOR USE

M1350-9001S

Printed in Germany March 2002

Edition 1



# **PHILIPS**

Philips makes no warranty of any kind with regard to this material, including, but not limited to, the implied warranties of merchantability and fitness for a particular purpose. Philips shall not be liable for errors contained herein or for incidental or consequential damages in connection with the furnishing, performance or use of this material.

The information contained in this document is subject to change without notice.

Philips assumes no responsibility for the use or reliability of its software on equipment that is not furnished by Philips.

## **Responsibility of the Manufacturer**

Philips only considers itself responsible for any effects on safety, reliability and performance of the equipment if:

- assembly operations, extensions, re-adjustments, modifications or repairs are carried out by persons authorized by Philips, and
- the electrical installation of the relevant room complies with national standards, and
- the instrument is used in accordance with the *Instructions for Use* or *User's Guide*.

## **Intended Use (M1350B)**

The Series 50 XM Fetal/Maternal Monitor (M1350B) allows non-invasive or invasive monitoring of an ambulant patient during both antepartum testing and labor and delivery in that the monitoring of the fetal heart rate (FHR) via ultrasound or direct electrocardiogram (DECG), and uterine activity via an external Toco transducer or an internal intrauterine pressure (IUP) transducer is possible, additionally it allows maternal heart rate recording via the MECCG transducer. Alarms are generated from maternal heart rate.

The Series 50 XM allows the non-invasive measurement of the Noninvasive Blood Pressure and the Oxygen Saturation parameters, generate alerts, and the generation of alerts and recordings on maternal patients.

The device is intended to be used in Labor-Rooms and Delivery-Rooms and in Antepartum-Testing-Areas. It is not intended to be used for transport monitoring and home use.

## Intended Use (M1350C)

The Series 50 XMO Fetal/Maternal Monitor (M1350C) allows non-invasive or invasive monitoring of an ambulant patient during both antepartum testing and labor and delivery in that the monitoring of the fetal heart rate (FHR) via ultrasound or direct electrocardiogram (DECG), and uterine activity via an external Toco transducer or an internal intrauterine pressure (IUP) transducer is possible, additionally it allows maternal heart rate recording via the MECG transducer. Alarms are generated from maternal heart rate.

The Series 50 XMO allows the non-invasive measurement of the Noninvasive Blood Pressure and the Oxygen Saturation parameters, generate alerts, and the generation of alerts and recordings on maternal patients. Additionally, the Series 50 XMO allows you to record fetal pulse oximetry (FSpO<sub>2</sub>).

The device is intended to be used in Labor-Rooms and Delivery-Rooms and in Antepartum-Testing-Areas. It is not intended to be used for transport monitoring and home use.

The Series 50 XMO (M1350C) is not available in the U.S.A.

## Conventions Used in This Guide

---

### **Warning**

**A warning alerts you to a potential serious outcome, adverse event or safety hazard. Failure to observe a warning may result in death or serious injury to the user or patient.**

---

### **Caution**

**A caution alerts you where special care is necessary for the safe and effective use of the product. Failure to observe a caution may result in minor or moderate personal injury or damage to the product or other property, and possibly in a remote risk of more serious injury.**

---

***Note***—A note calls your attention to an important point in the text.



On your monitor, this sign indicates that there is detailed information in this book which you must read before proceeding with your task

The monitor should only be used by, or under the direct supervision of, a licensed physician or other health care practitioner who is trained in the use of fetal and maternal heart rate monitors and in the interpretation of fetal and maternal heart rate traces. US law restricts this device to sale by, or on the order of, a physician.

© 2002 Philips Medizinsysteme GmbH

All rights are reserved. Reproduction in whole or in part is prohibited without the prior written consent of the copyright holder.

# Contents

<b>1. Safety</b> .....	<b>1</b>
General Safety Information .....	1
Electrical Safety .....	2
Maximum Input/Output Voltages .....	3
Service Socket for Upgrade Key .....	5
Protective Earth .....	5
Environment .....	6
Spillage .....	7
Electromagnetic Compatibility (EMC) .....	7
EMC Testing .....	7
System Characteristics .....	8
Avoiding Interference .....	9
ESU, MRI and Defibrillation .....	9
Leakage Current .....	10
<b>2. Overview</b> .....	<b>11</b>
About This Guide .....	11
About the Monitors .....	11
Major Parts and Keys .....	12
Cardio, Toco and FSpO <sub>2</sub> Channels .....	13
Maternal Parameters .....	15
Recorder Keys .....	17
Setting Keys .....	18
<b>3. General Information</b> .....	<b>19</b>
Introduction .....	19
Features .....	19
Suspected Fetal Demise .....	20
Fastening a Belt .....	21
Clipping a Transducer to the Belt .....	22
Attaching a Patient Module to the Belt .....	23
Connecting a Transducer or Patient Module to the Monitor .....	23
Signal Quality .....	24
Input Channels at a Glance .....	25
Example Trace .....	26
Marking an Event .....	27

<b>4. Getting Started</b> .....	<b>29</b>
Introduction .....	29
Before Connecting Power .....	29
Switching On the Monitor .....	30
Loading Paper .....	31
Switching on the Recorder .....	33
Displaying the Time and Date .....	34
Setting the Time and Date .....	34
Choosing Paper Speed .....	35
Setting the Paper Speed .....	36
Switching Off After Monitoring .....	37
<b>5. Monitoring FHR and FMP Using Ultrasound</b> .....	<b>39</b>
Introduction .....	39
What You Need .....	39
Getting Started .....	40
Fetal Movement Profile .....	42
FMP Statistics .....	42
Switching FMP Off and On .....	43
Using Keys .....	44
Using the Barcode Reader .....	44
Troubleshooting .....	45
<b>6. Monitoring FHR Using DECG</b> .....	<b>47</b>
Introduction .....	47
What You Need .....	48
Getting Started .....	49
Using the Traditional Open-wire Method to Monitor DECG .....	50
With DECG legplate M1357A .....	50
With Patient Module M1364A or M1365A .....	51
Using the DECG Adapter Cable M1362B to Monitor DECG .....	53
With DECG Legplate M1357A .....	53
With Patient Module M1364A or M1365A .....	56
Monitoring DECG .....	59
Why use Arrhythmia Logic? .....	60
After Monitoring .....	60
Troubleshooting .....	61
Heart Rate Out of Limits .....	62

<b>7. Monitoring Twin FHRs.</b> . . . . .	<b>63</b>
Introduction . . . . .	63
Things to Remember During Monitoring . . . . .	63
Monitoring Internally . . . . .	64
Monitoring Externally . . . . .	64
Separating Twin FHR Traces . . . . .	65
Twins Offset: On . . . . .	66
Twins Offset: Off . . . . .	67
Troubleshooting . . . . .	67
<b>8. Monitoring Uterine Activity</b> . . . . .	<b>69</b>
Introduction . . . . .	69
External Toco Monitoring . . . . .	69
Internal Toco Monitoring (IUP Monitoring) . . . . .	70
Troubleshooting . . . . .	71
External Toco . . . . .	71
Internal Toco . . . . .	72
<b>9. Fetal Pulse Oximetry.</b> . . . . .	<b>73</b>
Introduction . . . . .	73
Before You Start . . . . .	73
To Begin Monitoring . . . . .	74
Understanding the Display . . . . .	75
Alarm . . . . .	77
Alarm Limits . . . . .	77
Triggering an Alarm . . . . .	78
Acknowledging an Alarm . . . . .	78
Turning the Alarm On and Off . . . . .	78
Changing Alarm Limits . . . . .	78
Inop Alarms . . . . .	79
Troubleshooting . . . . .	80
Loss of Pulse Signal . . . . .	81
Inaccurate Measurements . . . . .	81
<b>10. Monitoring Using External Devices</b> . . . . .	<b>83</b>
Introduction . . . . .	83
Recording From an External Device . . . . .	84
What You Need . . . . .	85
Connecting the External Devices to the Monitor . . . . .	85

Example Trace .....	88
Trace Display on External Monitoring Systems .....	89
Troubleshooting .....	90
FSpO <sub>2</sub> .....	90
External Devices .....	91
<b>11. Recording Notes .....</b>	<b>93</b>
Introduction .....	93
Recording A Note .....	93
Deleting a Barcode Note .....	94
Recording Several Barcodes as One Note .....	94
Recording Several Barcodes as Separate Notes .....	95
Recording a Patient's Name .....	96
<b>12. Fetal Heart Rate Alerting .....</b>	<b>97</b>
Introduction .....	97
Alerts .....	97
Recognizing an Alert .....	97
Acknowledging an Alert .....	97
Turning Alerting ON or OFF .....	98
Changing Alert Limits .....	98
<b>13. Non Stress Test Timer .....</b>	<b>99</b>
Introduction .....	99
Setting the NST Timer .....	99
<b>14. Maternal Monitoring - Overview .....</b>	<b>101</b>
Introduction .....	101
Maternal Parameters - Overview .....	102
Softkeys .....	103
Reset Key .....	103
Power on Screen .....	104
To Begin Monitoring Immediately .....	104
Maternal Main Screen .....	104
Returning to the Maternal Main Screen .....	106
Alarms - Overview .....	106
Acknowledging an Alarm .....	106
Reviewing All Alarm Settings .....	106
Setting an Alarm .....	107



Warning Messages . . . . .	107
Acknowledging a Warning Message. . . . .	107
Volume and Contrast Control. . . . .	108
<b>15. Non-invasive Blood Pressure Monitoring. . . . .</b>	<b>111</b>
Introduction . . . . .	111
To Begin Monitoring . . . . .	111
Setup Screen. . . . .	112
Measurement Modes . . . . .	113
Changing Measurement Mode . . . . .	114
Pulse Rate. . . . .	115
Alarms. . . . .	115
Turning Alarms On and Off . . . . .	116
Changing Alarm Limits. . . . .	117
Recording. . . . .	118
Troubleshooting. . . . .	118
Warning Messages. . . . .	118
Measuring Problems. . . . .	119
Limitations . . . . .	120
<b>16. Maternal ECG, Heart and Pulse Rate. . . . .</b>	<b>121</b>
Introduction . . . . .	121
To Begin Monitoring . . . . .	121
Connecting the Transducer. . . . .	122
Applying the Electrodes. . . . .	123
Using MECG transducer M1359A. . . . .	124
Using a Patient Module (M1364A or M1365A) . . . . .	125
Cross-Channel Verification . . . . .	125
Displaying the MECG Waveform. . . . .	126
Changing Display Speed. . . . .	127
Freezing and Printing . . . . .	127
Maternal Heartrate Source . . . . .	127
Alarm (MECG and SpO <sub>2</sub> ). . . . .	128
Turning Alarms On and Off . . . . .	129
Changing Alarm Limits. . . . .	130
Troubleshooting. . . . .	131
<b>17. Maternal Pulse Oximetry (SpO<sub>2</sub>) . . . . .</b>	<b>133</b>
Introduction . . . . .	133
To Begin Monitoring Immediately . . . . .	133

Alarm (SpO <sub>2</sub> ) . . . . .	134
Turning Alarm On and Off. . . . .	134
Changing Alarm Limit. . . . .	134
Alarm (Pulse rate) . . . . .	135
Troubleshooting . . . . .	135
Warning Messages . . . . .	135
Limitations . . . . .	136





## **18. Maintenance and Performance Assurance . . . . . 139**

Preventive Maintenance . . . . .	139
Visual Inspection. . . . .	139
Routine Inspection . . . . .	139
Mechanical Inspection . . . . .	140
Calibration and Electrical Safety Checks . . . . .	140
Disposal. . . . .	140
Care and Cleaning. . . . .	141
Care of the Fetal Monitoring System. . . . .	141
Monitor. . . . .	141
Transducers and Patient Modules . . . . .	142
Adapter Cables. . . . .	143
Cleaning. . . . .	143
Disinfecting . . . . .	145
Sterilizing. . . . .	146
Monitor, Patient Modules, Transducers . . . . .	146
Adapter cables M1347A, M1362B . . . . .	146
Adapter cables M1362A, M1363A. . . . .	146
IUP (1290C/CPJ840J5) . . . . .	147
IUP Transducer Adapter Cable . . . . .	147
Belts. . . . .	148
Reusable SpO <sub>2</sub> Transducers. . . . .	148
Non-invasive Blood Pressure Cuff . . . . .	148
Storing Recorder Paper . . . . .	148
Self Test. . . . .	150
Quick Test . . . . .	151
Parameter Test . . . . .	152
Testing Transducers . . . . .	154
Toco . . . . .	154
Ultrasound . . . . .	154
IUP . . . . .	155
ECG . . . . .	155
Replacing the Batteries. . . . .	156
Replacing the Fuses. . . . .	157

<b>19. Troubleshooting</b> .....	<b>159</b>
Introduction .....	159
Error Messages .....	160
<b>20. Accessories</b> .....	<b>163</b>
Introduction .....	163
Standard Accessories .....	163
Fetal Accessories .....	163
Maternal Accessories .....	164
Documentation .....	164
Optional Accessories .....	164
Paper .....	166
Gels .....	166
Transducers and Patient Modules .....	167
MECG Electrodes and Cables .....	167
DECG Cables .....	168
Disposable Scalp Electrodes .....	168
Fetal Oxygen Sensor .....	169
IUP Transducers .....	169
IUP Catheters .....	169
Domes .....	170
IUP Transducer Holder .....	170
Maternal Accessories .....	170
NIBP Accessories .....	170
SpO <sub>2</sub> Accessories .....	171
Adapter Cables .....	171
Belts and Buttons .....	172
<b>21. Specifications</b> .....	<b>173</b>
Introduction .....	173
Patient Safety .....	173
Operating and Environmental .....	174
Fetal Display .....	175
Maternal Non-invasive Blood Pressure .....	175
Maternal Pulse Oximetry .....	177
Maternal ECG and Heart Rate .....	177
Maternal Display Section .....	178
Numerical Display .....	178
Maternal Display .....	178
Mode Display .....	178

Ultrasound, External and Internal Toco.....	179
Recorder .....	179
FHR (Cardio) Scales .....	180
Testing Facilities .....	180
Declaration .....	181
<b>22. Warranty .....</b>	<b>183</b>
Manufacturer's Responsibility.....	183
Warranty.....	183
<b>23. Training Evaluation .....</b>	<b>187</b>
M1350 XM, XMO Fetal Monitoring Lab Evaluation.....	187
Competency Statement .....	187
Performance Objectives.....	187
Maternal Parameters .....	188
Fetal SpO2 .....	188
Fetal Telemetry .....	188
Resources.....	188
Fetal Monitor Lab Evaluation .....	189
Maternal Parameters .....	192
Fetal SpO2 .....	193
Fetal Telemetry .....	194
Answers .....	194
Maternal Parameters .....	198
Fetal SpO2 .....	199
Fetal Telemetry .....	199

## General Safety Information

	<p>This symbol indicates that you should consult the <i>Instructions For Use</i> (this guide), and particularly any warning messages.</p>
	<p><b>Equipotential Terminal</b></p> <p>This symbol identifies terminals which are connected together, bringing various equipment or parts of a system to the same potential. This is not necessarily earth potential. The value of potentials of earth may be indicated adjacent to the symbol.</p>
	<p><b>Protective Earth Terminal</b></p> <p>This symbol identifies the terminal for connection to an external protective earth system.</p>
<p>2 x 1.5 V</p> 	<p><b>Battery 2 x 1.5V</b></p> <p>This symbol identifies the battery holder containing two 1.5 V batteries.</p>

The monitor is designed to fulfil safety requirements according to IEC 60601-1/EN 60601-1 (Class I), UL 2601-1, CSA-C22.2 No 601.1-M90.





It complies with the essential requirements of the Medical Device Directive 93/42/EEC. The monitor is classed:

**ORDINARY EQUIPMENT** - Enclosed equipment protected against ingress of water.

**CONTINUOUS OPERATION** - Can be operated continuously.

The Series 50 XMO and the Series 50 XM are not “ECG-Monitors”, are not defibrillator-protected, and are not designed for direct cardiac application.

## Electrical Safety

Equipment	Equipment Type	Information
External Toco transducer (M1355A) and IUP quartz transducer (1290C) and IUP transducer (CPJ840J5)	B ⚡	Patient Connector is electrically isolated. Connecting the transducer to the Toco channel results in CF condition.
Ultrasound transducer (M1356A)	B ⚡	Connecting the transducer to a Cardio channel results in a B condition.
DECG transducer (M1357A) and MEEG transducer (M1359A)	CF 	Connecting the transducers to a Cardio channel results in a CF condition.
US/MEEG combi transducer (M1358A)	B ⚡ (Ultrasound) CF  (MEEG)	Connecting the combi transducer to the Cardio 1 channel results in a CF condition for MEEG and a B condition for US application.
SpO <sub>2</sub> transducer (M1191A) Adapter cable (M1940A)	CF 	Connecting the SpO <sub>2</sub> transducer results in a CF condition.
NIPB cuffs (M1574A and M1575A) Interconnect tubing (M1599A)	CF 	Connecting the NIBP tubing results in a CF condition.
FSpO <sub>2</sub> /ECG patient module (M1365A) ECG only patient module (M1364A)	CF 	Connecting a patient module results in a CF condition.

---

## Maximum Input/Output Voltages

The following diagram shows the sockets for peripheral devices.

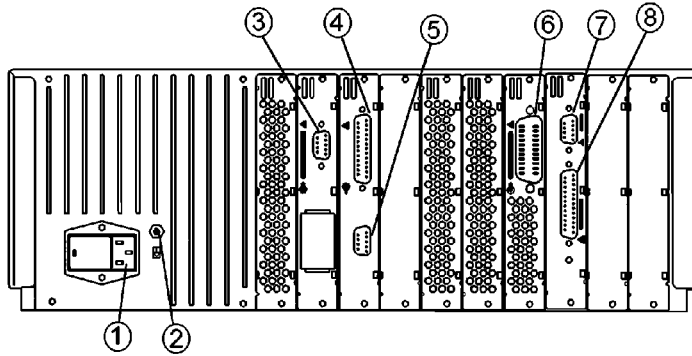

1. Mains Socket.
2. Equipotential Grounding Point.  
To use the monitor with other equipment in an operating room environment, connect the equipotential grounding point (2) to earth potential. Use the grounding cable supplied with the monitor.
3. +5V input socket for the HBSW8200 Barcode Reader.
4. Socket for the Philips M1310A Series 50 T Fetal Telemetry System. +5V input **except for:**
  - Pins 1, 14, 15 and 16:  $\pm 12V$  input
  - Pin 2 -12V output
  - Pin 3 +5V output
  - Pin 4  $\pm 12V$  output
5. RS232 Digital System Interface:
  - Pin2  $\pm 12V$  input
  - Pin 3  $\pm 12V$  output
6. Socket for one of the following:
  - 80225A or 80235A/B Obstetrical Information Management System (OBMS)
  - M1370A Obstetrical Display Information System (ODIS)
  - $\pm 12V$  except for Pins 17, 18 and 22 which are +5V input.
7. Socket (9-pin) for an external device:
  - Pin 3  $\pm 12V$
8. Socket (25-pin) for an external device:
  - Pin 2  $\pm 12V$
  - Pins 9 and 10 +5 Volt



---

## Service Socket for Upgrade Key

The Service Engineer can connect a compatible PC to this socket (1) to carry out extended configuration and service functions.

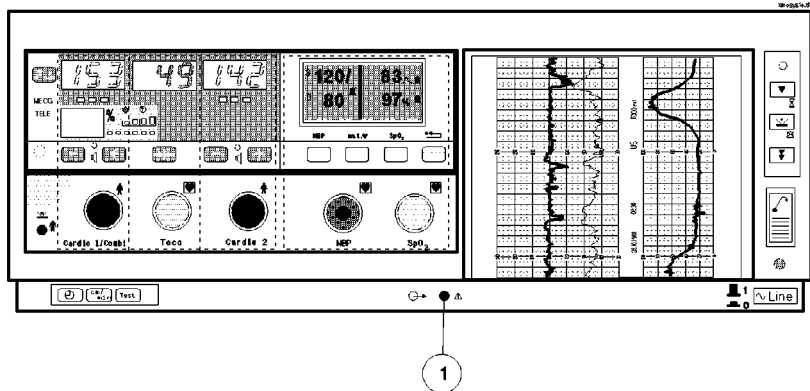

Maximum voltage of  $\pm 12V$ .

---

## Protective Earth

To protect hospital personnel and the patient, the monitor's casing must be grounded. Accordingly, the monitor has a 3-wire power cable that grounds it to the power line ground when plugged into an appropriate 3-wire receptacle. Do not use a 3-wire to 2-wire adapter with the monitor. Any interruption of the protective earth grounding will cause a potential shock hazard that could result in serious personal injury.

Whenever it is likely that the protection has been impaired, the monitor must be made inoperative and be secured against any unintended operation.

---

**Warning**

**Check each time before use that the monitor is in perfect working order and properly grounded.**

---

Position the patient cable so that it does not come into contact with any other electrical equipment. The cable connecting the patient to the monitor must be free of electrolyte.

Make sure that during operation, the monitor is free from condensation. This can form when equipment is moved from one building to another, and is exposed to moisture and differences in temperature.

---

**Warning**

**Possible explosion hazard if used in the presence of flammable anaesthetics.**

---

---

**Environment**

Use the monitor in an environment that is reasonably free from vibration, dust, corrosive or explosive gases, flammable agents, extremes of temperature, humidity and so forth. It operates within specifications at ambient temperatures between 0 and 55°C. Ambient temperatures that exceed these limits can affect the accuracy of the monitor and cause damage to the components and circuits. Only products that fulfil the necessary safety and electrical standards should be used in conjunction with the monitor (contact your local response center for details).

Allow at least 5cm (2in) clearance around the monitor for proper air circulation. If the monitor is mounted in a cabinet, allow sufficient space at the front for operation and at the rear for servicing with the cabinet door open.

---

## Spillage

When the maternal display is in a tilted position, take additional care to prevent spillage of liquid. If liquid accidentally enters the monitor through the maternal display recess, you must cease using the monitor immediately. Contact an authorized engineer for a safety inspection.

---

## Electromagnetic Compatibility (EMC)

The electromagnetic compatibility (EMC) validation includes testing performed according to the international standard for EMC with medical devices. See the Manufacturer's Declaration for details.

### EMC Testing

---

#### Caution

**If operating under conditions according to the EMC-standard 60601-1-2 (Radiated Immunity 3 V/m), field strengths above 1 V/m may cause erroneous measurements at various frequencies. Therefore it is recommended to avoid the use of electrically radiating equipment in close proximity to these measurements.**

---

During the test program the monitor was subjected to international standard and Philips proprietary EMC tests. During most of the testing no anomalies were observed. Some reduced performance was observed with the IEC 801-3 Radiated Immunity and IEC 801-4 Fast Transient/Bursts Immunity tests.

IEC 801-3 specifies that the product must be subjected to a field of 3V/m over a frequency range of 26 to 1000 MHz with no degradation of performance. At many of the test frequencies over the specified range no anomalies were observed. However increased jitter of SpO<sub>2</sub> values and DECG derived fetal heartrate values was observed at a number of test points. For these test points the radiated field was reduced to the level at which the trace returned to normal. These reduced levels are shown in the following table.

Parameter	Sensor	Frequency Range	Immunity Level
SpO <sub>2</sub>	M1191A M1192A M1194A	52 MHz to 70 MHz	2.3 V/m

IEC 801-4 specified that the product is subjected to high speed pulses up to 1000 V applied to the power cord and all I/O cables. During and after most of the test pulses, no anomalies were observed. However in rare cases the ultrasound channel had been triggered.

Parameter	Sensor	Burst Immunity Level
Ultrasound	M1356A M1358A	600 V
SpO <sub>2</sub> with adapter cable M1940A	M1191A M1192A M1194A	≤ 200V

### System Characteristics

The phenomena discussed above are not unique to the monitor but are characteristic of patient monitors in use today. This performance is due to very sensitive high gain front end amplifiers used to process the physiological signals from the patient. Among the many similarly performing monitors already in use by customers, interference from electromagnetic sources is rarely a problem.

## Avoiding Interference

When electromagnetic interference (EMI) is encountered there are a number of things that can be done to mitigate the problem.

1. Eliminate the source. Possible sources of EMI can be turned off or moved away to reduce their strength.
2. Attenuate the coupling. If the coupling path is through the patient cables the interference may be reduced by moving and/or rearranging the cables to a different location of the monitor. If the coupling path is through the power cord, plugging the monitor into a different mains circuit may help.
3. Connect the equipotential terminal of the monitor to the corresponding terminal of your mains installation.
4. Add external attenuators. If EMI becomes an unusually difficult problem, external devices such as an isolation transformer or a transient suppressor may help. An Philips customer engineer can assist you in determining the need for external devices.

---

## ESU, MRI and Defibrillation

---

### Warning

**Remove all transducers, patient modules, sensors and accessories before performing electrical surgery, defibrillation, and MRI. High frequency current can flow through the equipment and burn the skin.**

---

The equipment has not been tested with defibrillators.

---

## Leakage Current

Leakage current can be hazardous to the patient.

---

### **Warning**

**If the monitor is connected directly to other equipment, such as an additional patient monitor, or a second monitor is to be connected directly to the mother, you must carry out all relevant safety tests in accordance with safety standard IEC 60601-1-1.**

---

---

## About This Guide

This guide tells midwives, nurses and other healthcare professionals how to use the Series 50 XMO fetal/maternal monitor and the Series 50 XM fetal/maternal monitor. It discusses and illustrates all possible features and parameters of both monitors. Your monitor may not have every one of these features and may look slightly different to the monitor shown in the illustrations in this guide. It can be upgraded to incorporate them.

---

## About the Monitors

Both monitors let you observe and record:

- Fetal heart rate (including twins)
- Uterine activity
- Maternal heart rate (MHR) and ECG waveform
- Maternal pulse oximetry (SpO<sub>2</sub>)
- Fetal movement profile (FMP)
- Maternal blood pressure, non-invasively.

The Series 50 XMO also allows you to record fetal pulse oximetry (FSpO<sub>2</sub>).

You can monitor fetal heart rate externally with ultrasound from approximately 20 weeks and with the other parameters internally during labor and delivery.

Not all parameters and features detailed in this manual are available on all monitors.

## Major Parts and Keys

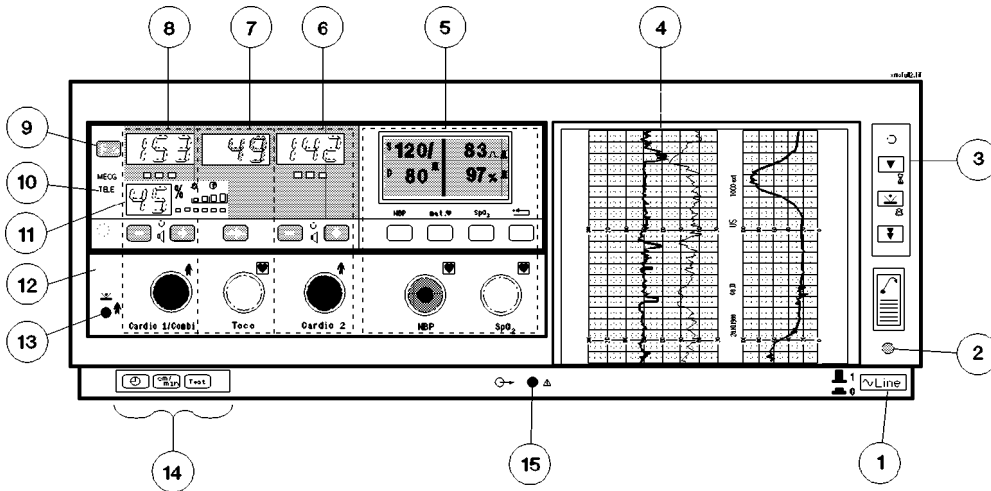

The display panel can be viewed flat in the monitor, or tilted at an angle.

- |                            |                                    |
|----------------------------|------------------------------------|
| 1. Monitor on/off switch   | 9. Function key                    |
| 2. Monitor on/off light    | 10. Telemetry indicator            |
| 3. Recorder keys           | 11. FSpO <sub>2</sub> parameter    |
| 4. Recorder                | 12. Opening recess                 |
| 5. Maternal parameters     | 13. Socket for remote event marker |
| 6. Cardio 2 channel        | 14. Setting keys                   |
| 7. Toco channel            | 15. Service socket                 |
| 8. Cardio 1/ combi channel |                                    |



## Cardio, Toco and FSpO<sub>2</sub> Channels

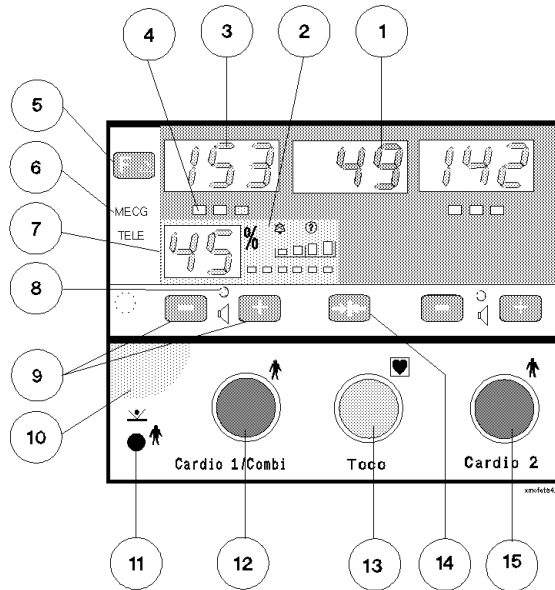

1. **Toco Display** shows uterine activity.
2. **Fetal SpO<sub>2</sub> display** shows fetal pulse indicator, signal quality, alarm status, and cross channel verification plus indicator.
3. **Cardio Display** shows the FHR.
4. **Signal Quality Indicator** shows the quality of heart rate signal detected by the transducer:
  - Green (good).
  - Yellow (fair to potentially poor).
  - Red (unacceptable).
5. **Function Key:** selects menus for:
  - FMP, twins offset, logic, FHR alert and FSpO<sub>2</sub>.
  - returns to the normal display.
6. **MECG Indicator** shows when MECG is being measured through this channel. (Indicator location different for Series 50 XM.)

7. **Fetal SpO<sub>2</sub> display** shows current value of FSpO<sub>2</sub>.
8. **Speaker Lamp** shows which heartbeat is heard from the loudspeaker.
9. **Volume Keys** set the volume and select the channel to which you are listening. Changes current setting of FMP, twins offset, logic, FHR alert and FSpO<sub>2</sub> alarms.
10. **Recess** for use when tilting the display.
11. **Remote Event Marker Socket** for connecting remote event marker (15249A).
12. **Cardio 1/Combi Transducer Socket** for connecting:
  - FSpO<sub>2</sub>/ECG combined patient module (M1365A).
  - ECG patient module (M1364A).
  - Ultrasound transducer (M1356A).
  - DECG transducer (M1357A).
  - US/MECG Combi transducer (M1358A).
  - MECG transducer (M1359A).
13. **Transducer Socket** for connecting:
  - external Toco transducer (M1355A).
  - IUP transducer (1290C, 13972A, or M1333A).
14. **Toco Baseline Key** zeroes the Toco display and trace to 20 units (when monitoring uterine activity externally) or 0 units (when monitoring uterine activity internally).
15. **Cardio 2 Transducer Socket** for connecting:
  - ECG patient module (M1364A).
  - US transducer (M1356A).
  - DECG transducer (M1357A).
  - MECG transducer (M1359A).

## Maternal Parameters

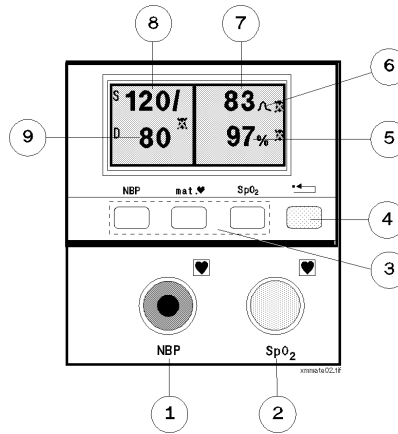

1. **NBP Transducer Socket** for connecting:
  - NBP cuff interconnect tubing (M1599A) and blood pressure cuff.
2. **SpO<sub>2</sub> Transducer Socket** for connecting:
  - SpO<sub>2</sub> transducer (M1940A adapter cable connected to M1191A transducer).
3. **Softkeys** for setting maternal parameters.
  - **NBP** selects modes and alarm limits for NBP.
  - **mat**  selects modes and alarm limits for MHR.
  - **SpO<sub>2</sub>** selects modes and alarm limits for SpO<sub>2</sub>.
4. **Reset Key** acknowledges alarms and returns monitor from setting mode to maternal parameter display.
5. **SpO<sub>2</sub> Value** indicates the current reading for patient's SpO<sub>2</sub> level.

6. **Maternal heart/pulse rate icon** indicates measurement source of maternal heart/pulse rate.

 indicates heart rate value comes from MECG.

 indicates pulse rate value comes from SpO<sub>2</sub>.

 indicates average pulse rate value comes from NIBP.

7. **Maternal Heart Rate** shows the current heart/pulse rate.
8. **Systolic Value** shows the value for the systolic parameter of the non-invasive blood pressure measurement.
9. **Diastolic Value** shows the value for the diastolic parameter of the non-invasive blood pressure measurement.

## Recorder Keys

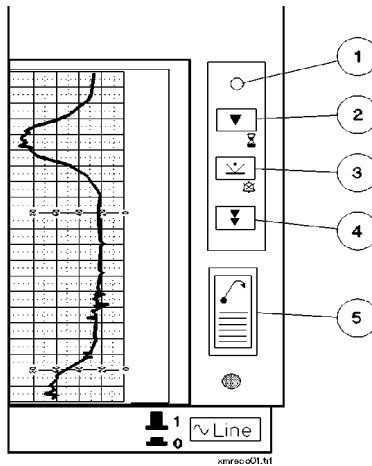

1. **Recorder On/Off Light** lights when the recorder is working. Flashes when monitor detects five or fewer pages remaining in the pack, or if the paper runs out.
2. **Recorder On/Off Key** switches recorder on and off. Also starts NST timer (switch off recorder and press for two seconds).
3. **Event Marker Key** records event on paper. Acknowledges all alerts and alarms.
4. **Paper Advance Key** advances paper automatically to the next fold. Tear paper at fold. Never pull paper to advance it.
5. **Paper-Eject Key** unlocks drawer when you press it once. Press a second time and hold when removing paper.

## Setting Keys

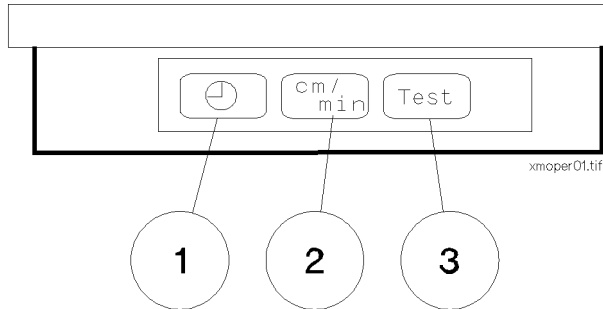

1. **Time and Date Key** for changing the time and date. Press to show the current time in the Cardio 1/Combi and Toco displays, to cycle through the settings to be changed (hours, minutes, day, month and year) and to return to the normal display.
2. **Paper Speed Key** for changing the paper speed. Press to show the current paper speed in the Cardio 1/Combi display, and to return to the normal display.
3. **Test Key** for starting monitor's self test.

# General Information

---

## Introduction

This section contains information common to a number of parameters and discusses the intended use of the monitor. Your monitor may not have all these features.

---

## Features

The Philips Series 50 XMO fetal/maternal monitor and the Philips Series 50 XM fetal/maternal monitor combine advanced fetal monitoring with integrated maternal non-invasive blood pressure, pulse oximetry and ECG measurement. Easy to use, they offer:

- Fetal pulse oximetry (FSpO<sub>2</sub>) measurement for direct, continuous assessment of fetal oxygenation during labor and delivery.
- Nellcor's fetal oxygen sensors.
- Maternal ECG waveform display.
- Automatic printing of maternal and fetal parameters on the trace.
- Transmission of maternal and fetal parameters to an obstetrical overview system.
- Audible and visual alarms.
- Gross fetal body movements (Fetal Movement Profile) and statistics recording for advance information on fetal well being.
- Twin heart rate trace separation for easier interpretation.
- NST timer and paper-end alarm.
- Watertight transducers.
- Heart rate/pulse rate from maternal ECG, SpO<sub>2</sub> or NIBP.

The monitors give you flexible monitoring capability for both high-risk patients and those with normal labor and delivery. Both monitors can measure traditional fetal parameters, including twins. Maternal vital signs - blood pressure, pulse oximetry, and maternal ECG - are monitored non-invasively. These are displayed on a tiltable LCD screen. When monitoring maternal ECG, you can display and freeze the waveform on the LCD screen to assist in interpretation. You can also print the waveform on the FHR trace.

The Series 50 XMO also offers measurement of fetal pulse oximetry. Based on proven technology from Nellcor, it monitors fetal oxygen saturation during labour and delivery. This is non-invasive to the fetus and non-traumatic to the mother. Fetal pulse oximetry gives status information about fetal oxygenation to help you interpret non-reassuring fetal heart rate traces.

---

## Suspected Fetal Demise

Be very careful when interpreting a trace if you suspect fetal demise. The maternal heartrate may be atypically high and therefore confused with that of a live fetus. Apparent fetal movement may also be detected by the monitor but this may be a result of maternal movement causing the fetus to move within the amniotic fluid. Please refer to "Cross-Channel Verification" on page 125.



---

## Fastening a Belt

Arrange the belt around the patient until it is tight but still comfortable. Fasten it by pushing the fixing button through the overlapping section of the belt, with the point facing away from the patient. Ensure that the fixing button and the loose ends of the belt are at the patient's side.

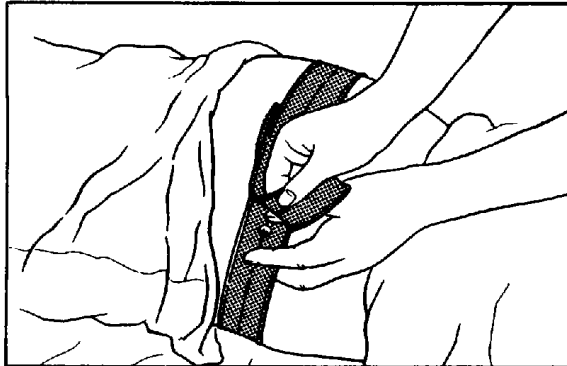

You can use more than one belt if, for example you are measuring fetal heart rate using ultrasound and uterine pressure simultaneously.

---

## Clipping a Transducer to the Belt

When you have positioned a transducer satisfactorily, you can clip it to the belt.

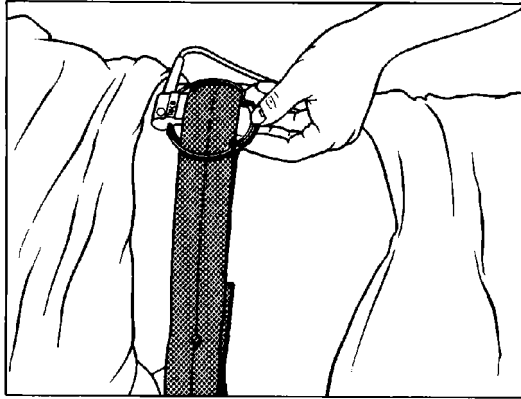

Alternatively, you can affix a button to the transducer and use this to attach the transducer to the abdominal belt. See the Installation Note that comes with the Transducer Knob Adapter for assembly instructions.

---

## Attaching a Patient Module to the Belt

You can attach a patient module to the belt by sliding the patient module under the belt and pushing the fixing knob (1) on the patient module through one of the holes in the belt.

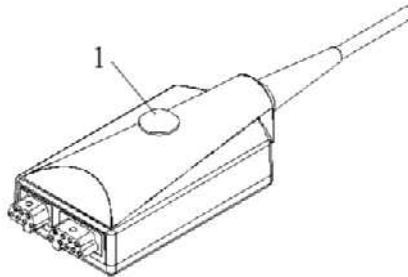

---

## Connecting a Transducer or Patient Module to the Monitor

When you connect a transducer or patient module to either the Cardio 1/ Combi socket, the Toco socket or the Cardio 2 socket, the three dashes in the display go out. The signal quality light for the heart rate display turns red (because the transducer is not yet receiving a good signal from the patient). The monitoring mode is printed on the paper, and repeated every three to four pages.

If you are measuring:

- Uterine activity, the display jumps to 20 (the Toco baseline).
- Intrauterine pressure, the display shows 0.

---

### **Warning**

**NEVER immerse a transducer in liquid when it is connected to the fetal monitor.**

---

---

## Signal Quality

During monitoring, if the signal quality indicator fluctuates between red, yellow and green, it does not necessarily mean that the transducer needs repositioning. The fluctuation may be caused by fetal movement. Allow time for the signal to stabilize before deciding whether to reposition the transducer (ultrasound) or apply a new electrode (ECG). A trace is possible when the indicator is yellow, but for the best trace it should be continuously green.

***Note***— **Disconnect NON-USED ultrasound transducer, as continuous mechanical influence of the transducer may result in an artificial trace.**

## Input Channels at a Glance

This table indicates which combination of transducers and patient modules you can use in the Cardio input sockets.

Cardio1/Combi	Cardio 2	Measurements
US (M1356A)	US (M1356A or M1358A)	Dual ultrasound.
	DECG (M1357A or M1364A)	Single ultrasound and fetal ECG.
FSpO2/ECG combined patient module (M1365A): with DECG adapter cable (M1362A or M1362B)	US (M1356A)	Fetal SpO2 with fetal ECG and single ultrasound.
	MECG (M1364A or M1359A)	Fetal SpO2 with fetal ECG and maternal ECG.
with MECG adapter cable (M1363A)	US (M1356A)	Fetal SpO2 with maternal ECG and single ultrasound.
ECG only patient module (M1364A): with MECG adapter cable (M1363A)	US (M1356A)	Maternal ECG and single ultrasound.
	DECG (M1357A or M1364A) with DECG adapter cable (M1362A or M1362B)	Maternal ECG and fetal ECG.
DECG adapter cable (M1362A or M1362B)	US (M1356A)	Fetal ECG and single ultrasound.
	MECG (M1359A or M1364A) with MECG adapter cable (M1363A)	Fetal ECG and maternal ECG.
DECG (M1357A)	US (M1356A)	Fetal ECG and single ultrasound.
MECG (M1359A)	US (M1356A)	Maternal ECG and single ultrasound.
	DECG (M1357A or M1364A or M1365A)	Maternal ECG and fetal ECG.
US/MECG (M1358A)	DECG (M1357A or M1364A) with DECG adapter cable (M1362A or M1362B)	Single ultrasound with maternal ECG and fetal ECG.
	US (M1356A)	Single ultrasound with maternal ECG and second ultrasound.

You can use the combined US/MECG transducer (M1358A) in the Cardio 2 socket to measure ultrasound only. However if you want to use the combination of US/MECG, you must connect it to the Cardio 1/ Combi socket.

## Example Trace



1. Manufacturer's logo.
2. Time, date and paper speed.
3. Barcode notes.
4. Fetal movement profile.
5. Fetal blood oxygen saturation level (FSpO<sub>2</sub>) trace.
6. Uterine activity trace.
7. Maternal heart rate (78 bpm) (either SpO<sub>2</sub> or NBP pulse rate).
8. Maternal blood pressure:
  - Systolic blood pressure is 128 mmHg.
  - Diastolic blood pressure is 98 mmHg.
  - Mean arterial pressure is 109 mmHg.
9. Maternal temperature (37.5°C). An asterisk \* marks measurements from external devices.
10. Maternal blood oxygen saturation level (97%).
11. Maternal heart rate trace (either MCECG or SpO<sub>2</sub> pulse).
12. Fetal heart rate from Ultrasound or DECG.

Your trace may not look exactly like this - the actual appearance depends on which options you have installed, and which features are in use.

---

## Marking an Event

Use the event marker key or the remote event marker to record significant events on the paper (for example, when pain medication is administered or when the mother changes position). To mark an event on the paper:

- Press the event marker key on the monitor or
- Press the button on the remote event marker.

A small arrow (A) prints on the FHR Scale. The arrow starts with the peak to show the exact time when the key or button is pressed. If the key or button is not released, a black bar is printed on the paper. The width of the bar corresponds to the length of time the key or button is pressed.

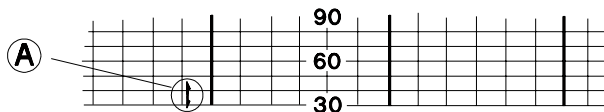

pap5bw.hpg

## Marking an Event



# 4

## Getting Started

---

### Introduction

This chapter tells you how to prepare your monitor to begin monitoring your first patient. You should:

- Ensure that your monitor is set for the correct voltage for your country
- Check the time, date, and paper speed
- Load paper into the recorder.

---

### Before Connecting Power

Operate the monitor from an ac (alternating current) power source of

- 100 V ( $\pm 10\%$ )
- 120 V ( $\pm 10\%$ )
- 220 V ( $\pm 10\%$ )
- 240 V ( $\pm 10\%$ )

and 50 to 60 Hz ( $\pm 5\%$ ). The maximum power consumption is 60 VA.

Before connecting power, ensure that the voltage selector (A) on the monitor's rear panel shows the correct setting for your country.

To use the monitor with other equipment in an operating room environment, connect the equipotential grounding point (B) to earth potential. Use the grounding cable supplied with the monitor.

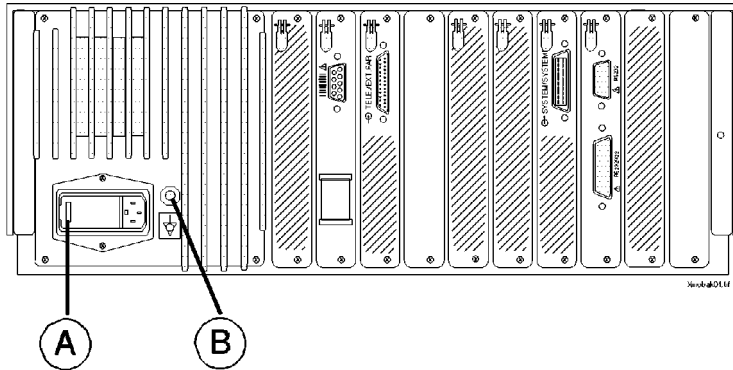

---

## Switching On the Monitor

Connect the power cord to the rear of the monitor.

Press **Line~** to switch on the monitor. When you switch on:

- The monitor on/off light and the displays come on.
- There are two clicks from the loudspeaker.
- The monitor carries out a self test. For details of the self test see page 150. The error messages that may be displayed are given in Chapter 19, “Troubleshooting”.
- The maternal display screen shows an egg-timer symbol for a few seconds and then its alarm parameters screen.
- All parameter displays show two or three dashes, indicating there is no transducer or patient module plugged in.
- The maternal display lights up, showing the default alarm parameters.

---

## Loading Paper

To load a new pack of paper:

- a. Switch off the recorder.

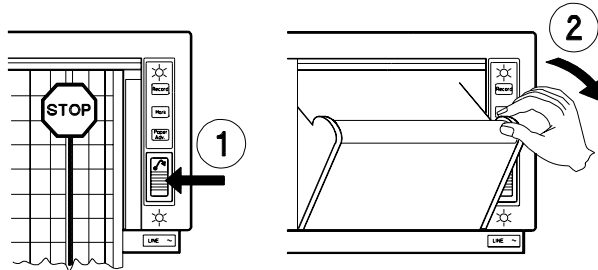

rep5\_bw.hpg

- b. Push the paper-eject key (1) to unlock the drawer. Make sure that the drawer is fully open (2).
- c. Push and hold the paper-eject key and lift out any remaining paper.
- d. Place the new paper in the tray with the bottom side down. The bottom side is indicated by the word STOP on the final page of the new pack.
- e. Unfold the top page of the pack.

f. Position the uterine activity scale on the right.

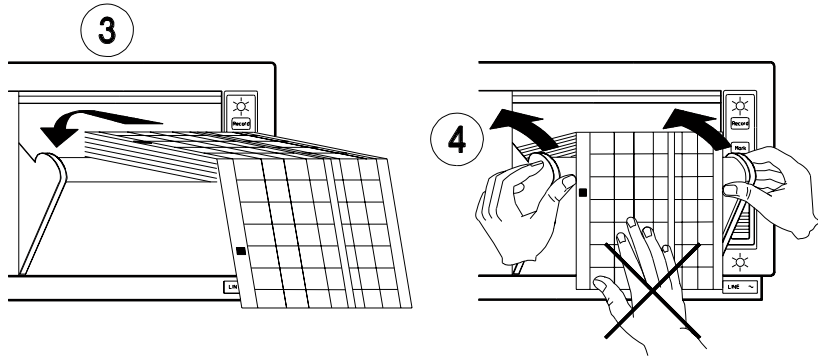

rep6\_bw.jpg

g. Slide the pack into the tray (3).

h. Push the drawer back until it “clicks” closed. Don’t push on the paper when closing the drawer (4).

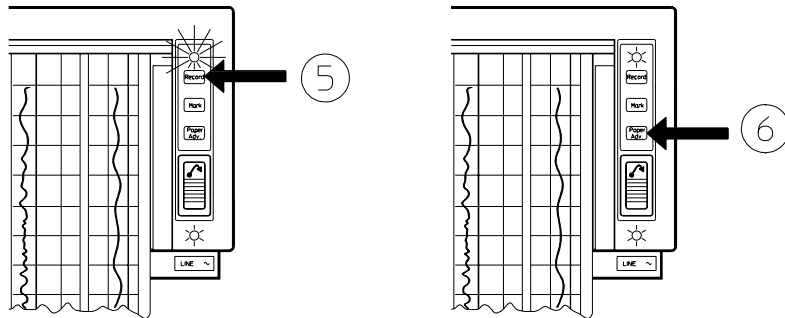

pega73\_bw.jpg

i. Press the recorder on/off key(5) to switch on the recorder. If the recorder on/off light flashes after the paper is loaded and the recorder is switched on, the drawer is not closed properly.

j. Press and release the paper advance key (6) to advance the paper automatically to the next fold. Check that the paper feeds straight.

---

**Caution**

**Using recorder paper that is not approved by Philips can damage the monitor. This type of damage is not covered by warranty.**

---

If you have difficulty removing the paper, ensure that you have pushed the paper-eject key twice. The first push releases the paper drawer. The second push engages the paper eject mechanism which pushes the remaining paper up the drawer towards you, making it easy to remove.

---

## Switching on the Recorder

Press the recorder on/off key to switch on the recorder if necessary. When you switch on:

- The recorder on/off light comes on.
- The paper advances quickly for 2 cm and then returns to the set speed.
- The time, date and paper speed are printed.
- The current monitoring modes (if any transducers are connected to the monitor) are printed.

The monitor prints the time, date, paper speed and monitoring modes when first switched on, every ten minutes after, and if the monitoring modes change.

The recorder on/off light flashes when the monitor detects that there are five pages or fewer remaining in the pack. If you switch on the recorder or press the paper advance key when there are fewer than five pages remaining, it may take two pages before the recorder on/off light flashes. Load a new pack as soon as possible.

---

## Displaying the Time and Date

The date and time are printed on the trace. You can choose from a variety of standard date and time formats, such as 12 hour format or 24 hour format, US or European date format. If you have a barcode reader you can change the time and date display format by scanning the desired format from the barcode sheet. If you do not have a barcode reader, you can set the desired format using a service setting. See the Installation and Service Guide for this monitor for instructions.

---

## Setting the Time and Date



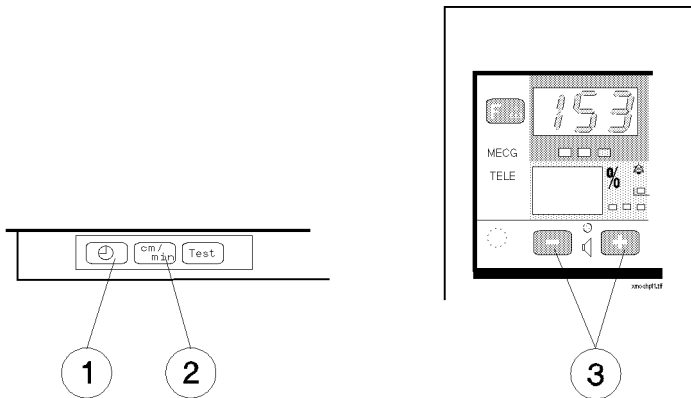



Use the following keys to view and change the time and date:



1. **Clock key** displays the time.
2. **Paper speed** displays the paper speed.
3. **Volume keys** change the time, date and paper speed.

After you make changes and return to the normal display, the new time and date are set, and the time, date and paper speed are printed on the paper immediately and then every 10 minutes. You return to the normal display automatically if you don't press any key for a few seconds.

**To set the time and date:**

1. Press and release  to display the current time. The Cardio 1/Combi display flashes to show that the hour can be changed.
2. Press  or  to set the hour. Press and hold the keys to change the setting more quickly.
3. Press and release  and the Toco display flashes to show that the minutes can be changed.
4. Press  or  to set the minutes.
5. Repeat the procedure:
  - a. To set the month (in North America) or the day (in other countries).
  - b. To set the day (in North America) or the month (in other countries).
  - c. To set the year.
6. Press and release  to return to the normal display.

---

## Choosing Paper Speed

You can choose a paper speed of 1, 2 or 3 centimeters per minute (cm/min). The default for North America is 3 cm/min; the default for other countries is 2 cm/min.

The ACOG technical bulletin on FHR monitoring states that “*accurate pattern recognition is difficult if not impossible at 1 cm/min and that 1 cm/min is only recommended for more economic screening. When FHR abnormalities arise, the faster paper speeds will enhance FHR pattern recognition*”.





Additionally, because a change in paper speed results in a change in the appearance of an FHR trace, you are advised to ensure **ALL** monitors in your institution are set at the same speed.

---

## Setting the Paper Speed

Use the paper speed key to display the current paper speed and to return to the normal display. You also return to the normal display automatically if you don't press any key for a few seconds. Use the volume keys to change the speed. When you return to the normal display, the new paper speed is set, and the time, date, speed and monitoring modes are printed on the paper.

To set the paper speed:

1. Press and release  to display the current speed.
2. Press  or  to set the speed.
3. Press and release  to return to the normal display.



---

## Switching Off After Monitoring

1. Switch off the recorder (1).
2. Press and release the paper advance key (2) to advance the paper automatically to the next fold.
3. While you wait for the paper to advance to the next fold, remove the transducers from the patient. Use a soft tissue to remove any gel from the transducers.
4. Tear off the paper at the fold (3). Don't pull on the paper to advance it, and tear off the paper at the fold only.
5. Switch off the monitor.

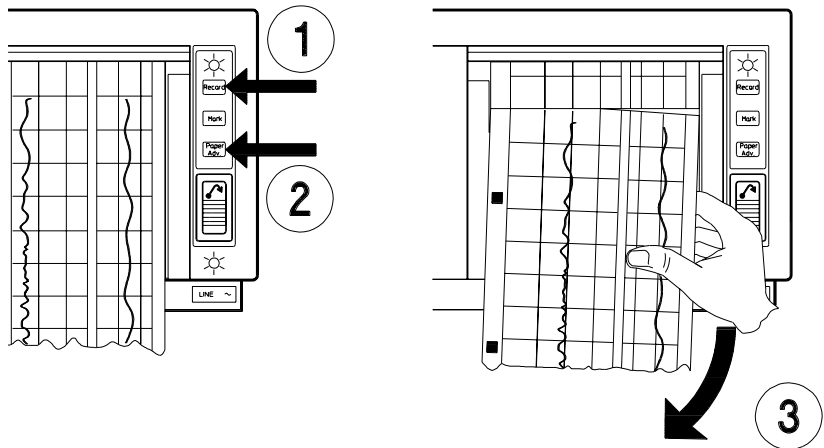

Switching Off After Monitoring

# Monitoring FHR and FMP Using Ultrasound

---

## Introduction

This chapter describes how to monitor a single fetal heart rate using ultrasound. Monitoring using ultrasound is recommended from the 25th week of gestation for non-stress or normal routine fetal monitoring. The monitor can also detect fetal movements and display the resulting fetal movement profile (FMP) on the trace.

---

### Warning

**NEVER immerse the ultrasound transducer in liquid when it is connected to the monitor.**

---

If you simultaneously monitor a single FHR using both ultrasound and DĒCG, the ultrasound trace is delayed by approximately two to three beats per minute.

Performing ultrasound imaging or Doppler flow measurements together with the ultrasound fetal monitoring may cause false FHR readings, and the trace recording may deteriorate.

---

## What You Need

- Ultrasound transducer
- Gel
- Transducer belt and button

---

## Getting Started

1. Fasten the belt around the patient.
2. Switch on the monitor and the recorder.
3. Connect the transducer to either the Cardio 1/Combi socket, or to the Cardio 2 socket.

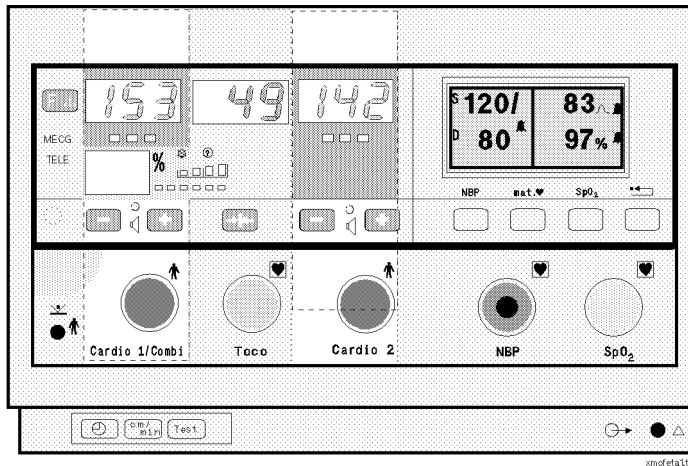

4. Find the fetal heart position by palpation, auscultation or ultrasound imaging.

---

### Caution

**Using ultrasound gel that is not approved by Philips may reduce signal quality and may damage the transducer. This type of damage is not covered by warranty.**

---

5. Apply a small amount of ultrasound gel in a thin layer to the transducer.

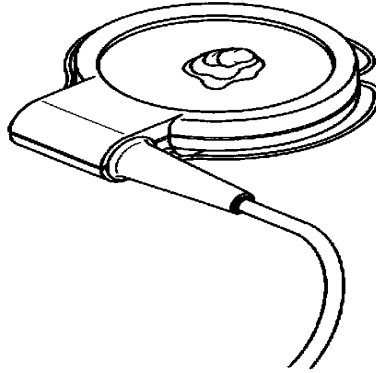

6. Apply the transducer to the patient, working it in a circular motion to ensure the gel layer makes good contact.
7. When you have a good signal, clip the transducer in position on the belt.

**Note—Disconnect NON-USED ultrasound transducers as the continuous mechanical influence of the transducer will result in an artificial trace.**

---

### **Warning**

**Periodically compare the mother's pulse with the signal coming from the monitor's loudspeaker to ensure that you are monitoring fetal heart rate. Do not mistake a doubled maternal heart rate for FHR. When you monitor maternal heart rate simultaneously with FHR, cross-channel verification alerting warns you if maternal and fetal heart rates coincide.**

---

Please refer to "Cross-Channel Verification" on page 125.

---

## Fetal Movement Profile

The monitor can detect fetal movements via an ultrasound transducer plugged into the Cardio 1/Combi socket. The resulting fetal movement profile (FMP) appears as “activity blocks” (A) along the top of the Toco Scale, the length of each block showing the duration of the activity.

### FMP Statistics

FMP Statistics (B) are printed below the activity blocks every 10 minutes.

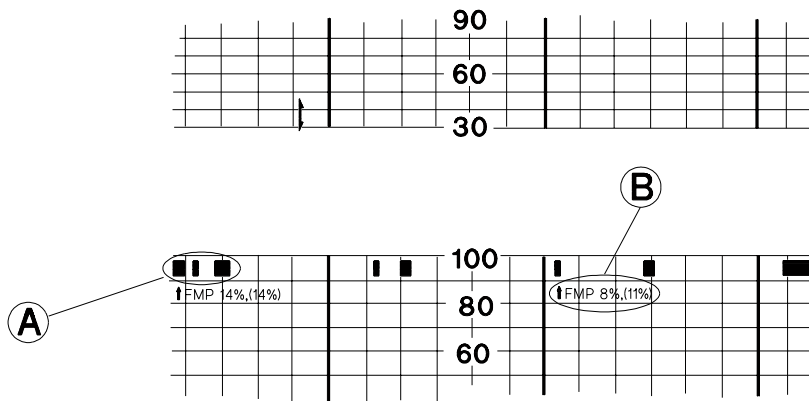

The first value shows the percentage of detected fetal movements in the previous 10 minutes, and the value in parentheses shows the percentage of detected fetal movements since the recorder was switched on. During the first 10 minutes of monitoring, the values will be identical.

If you plug an ultrasound transducer into the Cardio 1/Combi socket, FMP statistics start again from zero.

The FMP output activates after about half a minute of valid heart rate signals (green or yellow signal quality indicator) to minimize transducer positioning artifact. ↑ FMP is printed on the paper to mark the starting point of the FMP statistic.

***Note*—The transducer detects gross fetal body movements. Eye movements are not detected and movement of the feet and hands may not be detected. Positioning or repositioning the transducer is recorded as fetal movement. Maternal movement, excessive fetal breathing or fetal hiccups may also be recorded as fetal movement. You can mark this artifact on the paper using either the remote event marker or the event marker key. Ignore these movements when you interpret the FMP.**

When monitoring twins, remember that movements recorded for twin 1 may also be caused by movement of twin 2.

### Switching FMP Off and On

Switching the monitor on also switches FMP on, unless M1310A fetal telemetry is connected. You can use either the function key or the optional barcode reader to switch FMP off and on.

## Using Keys

You must connect an ultrasound transducer to the Cardio 1/Combi socket before you can change the FMP setting.

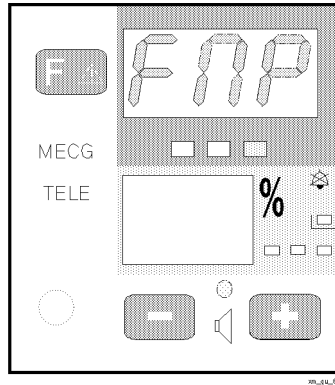

1. Press **F.A.** repeatedly until the monitor displays *FMP* .  
The Signal Quality Indicator shows:  
RED if FMP is OFF.  
GREEN if FMP is ON.
2. Press **-** or **+** to change the setting.
3. Press and release **F.A.** to return to the normal display.
4. FMP is printed on the paper.

You return to the normal display automatically if you don't press any key for a few seconds.

## Using the Barcode Reader

Enter FMP Off or FMP On from the barcode sheet.



## Troubleshooting

Problem	Possible Causes	Solutions
Erratic trace. Erratic display.	Fetal arrhythmia. Obese patient. Transducer wrongly positioned.  Belt loose. Too much gel. Very active fetus. Maternal movement. Insufficient gel.	None. None. Reposition transducer until signal quality indicator is green. Tighten belt. Remove excess. None. Relax the patient. Use recommended amount.
Signal quality indicator is red continuously.	Transducer wrongly positioned.  FHR less than 50 bpm.	Reposition transducer until signal quality indicator is green. None.
Questionable FHR.	Recording MHR by mistake. Recording periodic signals when the transducer is not applied to the patient.	Reposition transducer.
	FHR exceeds 300 bpm.	FHR is half-counted (for example 320 bpm is recorded as 160 bpm).
FHR not recorded.	FHR is less than 50 bmp or over 300.	None.
Light or no trace.	Wrong paper or dirty printhead.	Use recommended paper or clean printhead.
End of paper noted when pack not finished.	Bad paper feed or wrong paper.	Check paper feed and use recommended paper.
Error message is displayed.		See Chapter 19, "Troubleshooting" for a table of error messages, their causes and their solutions.
If you suspect the transducer.		Carry out the Parameter Test as described on page 152.
If you suspect the recorder or display.		Carry out the Quick Test as described on page 151.



# Monitoring FHR Using DECG

---

## Introduction

This chapter describes how to monitor a single fetal heart rate using a spiral Fetal Scalp Electrode.

Because the tip of the electrode penetrates the fetal epidermis, the possibility of trauma, hemorrhage and infection exists. Use the electrode only under aseptic conditions. Do not apply the electrode:

- To the fetal face, to the fontanel, or to the genitalia
- When placenta previa is present
- When you cannot identify the portion of the fetal body where application is contemplated
- Before the membranes are ruptured
- If genital infection exists
- When the patient is less than two centimeters dilated
- When the fetal station is less than minus two.

---

## What You Need

- If you are measuring fetal DECG using the traditional open-wire method with a legplate transducer:
  - DECG legplate transducer (M1357A)
  - Transducer leg belt and button
  - Open-wire Fetal Scalp Electrode (M15133A/M15133C).
- If you are measuring fetal DECG using the traditional open-wire method with a patient module:
  - Either ECG only patient module (M1364A) or FSpO<sub>2</sub>/ECG combined patient module (M1365A)<sup>1</sup>
  - Adapter cable (M1362A)
  - Pre-gelled electrode (40493E)
  - Open-wire Fetal Scalp Electrode (M15133A/M15133C).
- If you are measuring fetal DECG using the DECG Adapter Cable M1362B with a legplate transducer:
  - DECG legplate transducer (M1357A)
  - DECG adapter (M1347A)
  - DECG Adapter Cable (M1362B)
  - Transducer leg belt and button
  - Pre-gelled Pad Electrode (M1349A)
  - Fetal Scalp Electrode (15133E/15133D).
- If you are measuring fetal DECG using the DECG Adapter Cable M1362B with a patient module:
  - Either ECG only patient module (M1364A) or FSpO<sub>2</sub>/ECG combined patient module (M1365A)<sup>1</sup>
  - DECG Adapter Cable (M1362B)
  - Pre-gelled Pad Electrode (M1349A)
  - Fetal Scalp Electrode (15133E/15133D).

---

1. The FSpO<sub>2</sub>/ECG combined patient module (M1365A) can be used only with the Series 50 XMO Fetal Monitor (M1350C).

---

## Getting Started

Prepare as you would for a routine sterile vaginal examination. Ensure that the fetus is in a position to be monitored by DECG. Attach the electrode to the fetus as described in the instructions that come with the Fetal Scalp Electrode.

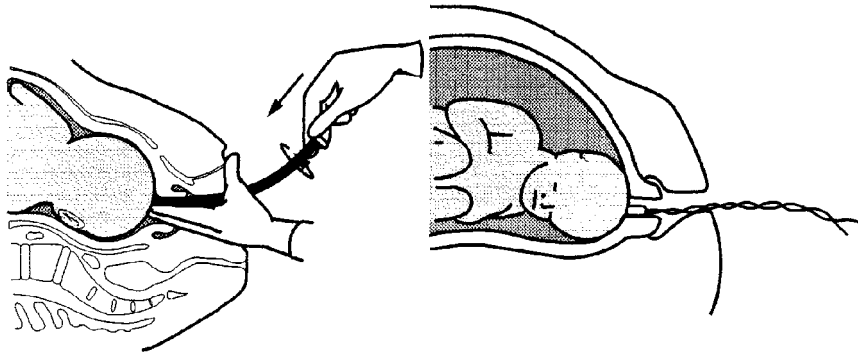

Attaching the Fetal Scalp Electrode

Fetal Scalp Electrode Attached

---

### **Warning**

**Do not insert the fetal scalp electrode wires into the AC mains socket.**

---

---

## Using the Traditional Open-wire Method to Monitor DECG

(applicable to Fetal Scalp Electrode 15133A and 15133C)

### With DECG legplate M1357A

To monitor fetal DECG using the traditional open-wire method and a DECG legplate M1357A, follow these instructions.

1. Fasten the belt around the patient's upper thigh. Ensure that the belt is correctly attached to prevent tension in the cable from pulling on the Fetal Scalp Electrode and injuring the fetus.
2. Slide the transducer under the belt, pointing the connectors towards the abdomen. To get the best signal the transducer must have good contact to the mother's skin. Do not apply Redux creme or any other conductive gel to the silver plate on the bottom of the DECG transducer.

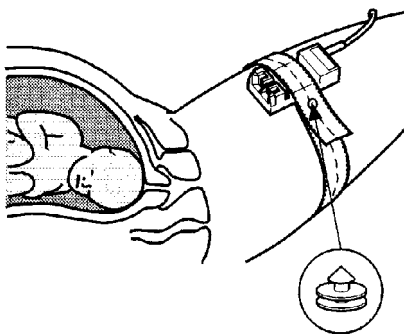

3. Connect the Fetal Scalp Electrode wires to the DECG transducer.

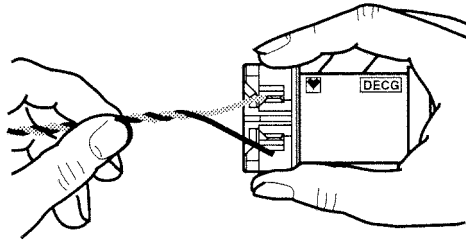

4. You are now ready to begin monitoring DECG: see the section “Monitoring DECG” for your next step.

### With Patient Module M1364A or M1365A

To monitor fetal DECG using the traditional open-wire method and either an ECG-only patient module (M1364A), or an FSpO<sub>2</sub>/ECG combined patient module (M1365A), follow these instructions.

1. Fix the DECG cable clip (2) to a pre-gelled electrode 40493E (1).
2. Connect the Fetal Scalp Electrode wires (3) to the DECG cable clip as shown below:

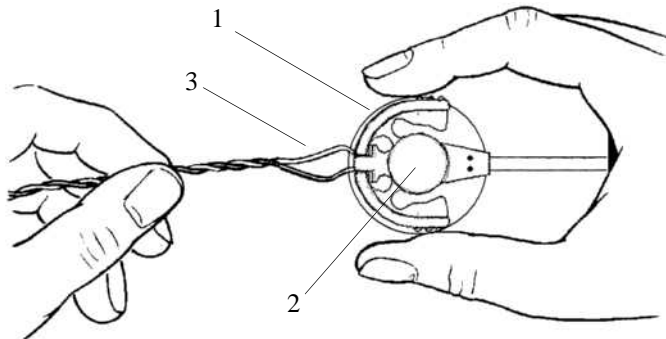

3. Peel the backing from the electrode (40493E) and affix it to the mother's thigh. A good contact between the electrode and the mother's skin will improve the FHR signal. To get the best signal, ensure that the skin is clean and dry before attaching the electrode.

Ensure that the electrode is correctly positioned to prevent tension in the cable from pulling on the Fetal Scalp Electrode and injuring the fetus.

4. Attach the pink connector (1) on the DECG Cable (M1362A) to the ECG pink connector (1) on the patient module (M1364A/ M1365A).

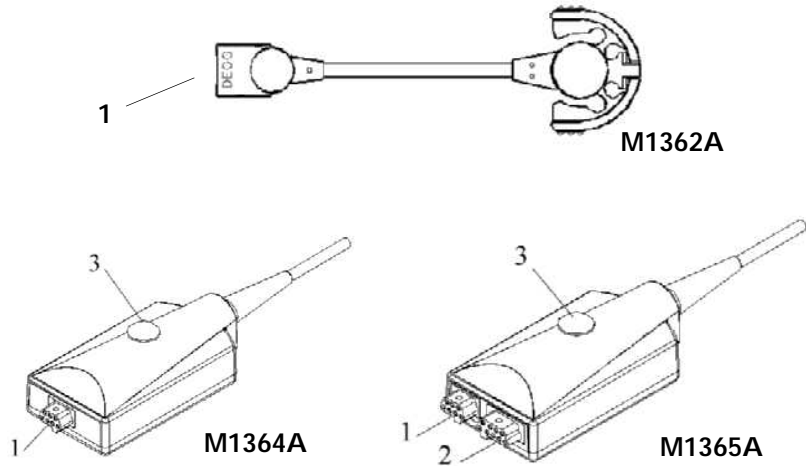

5. Position the patient module under the abdominal transducer belt wherever it is comfortable for the mother, securing it to the belt using the fixing knob (3).
6. You are now ready to begin monitoring DECG: see the section “Monitoring DECG” below for your next step.



---

## Using the DECG Adapter Cable M1362B to Monitor DECG (Applicable to Fetal Scalp Electrode 15133D/15133E)

### With DECG Legplate M1357A

To monitor fetal DECG using the DECG Adapter Cable (M1362B) and a DECG legplate transducer (M1357A), follow these instructions.

1. Connect the DECG adapter (M1347A) to the DECG legplate transducer (M1357A):
  - With the finger and thumb of one hand, press in the spring clips on the legplate.

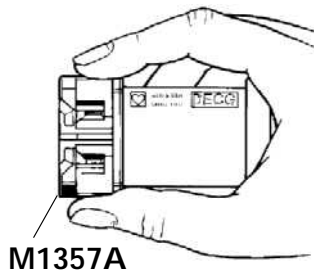

- Fit the DECG adapter (M1347A) onto the legplate and release the spring clips to lock the adapter into place.

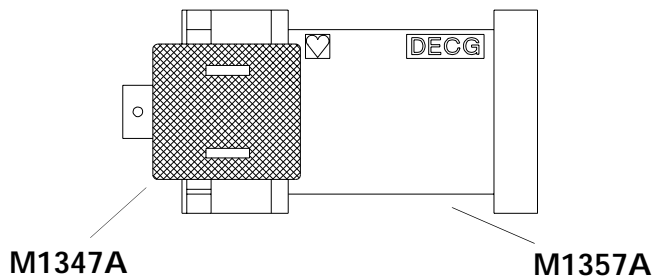

2. Secure the legplate transducer under the abdominal belt or under the leg belt. To get the best signal the transducer must have good contact to the mother's skin. Do not apply Redux creme or any other conductive gel to the silver plate on the bottom of the DECG transducer.

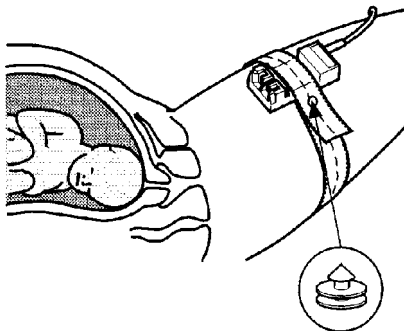

3. Attach a pre-gelled electrode (M1349A) to the DECG Adapter Cable (M1362B).

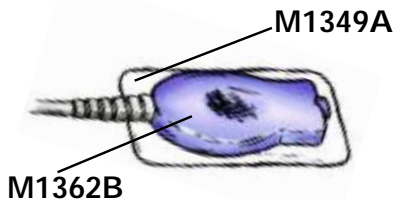

4. Connect the DECG Adapter Cable (M1362B) to the DECG Adapter (M1347A).

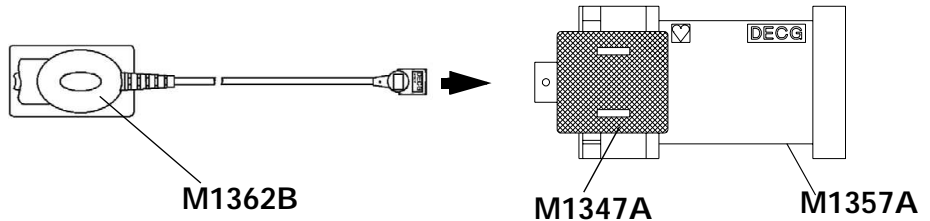

5. Connect the Fetal Scalp Electrode (15133D/15133E) to the DECG Adapter Cable (M1362B).

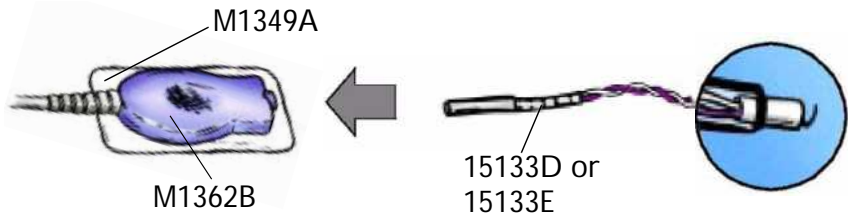

6. Peel the backing from the electrode (M1349A) and affix it to the mother's thigh. Make sure that the skin is clean and dry before attaching the electrode. Ensure that the electrode is correctly positioned to prevent tension in the cable from pulling on the Fetal Scalp Electrode and injuring the fetus.
7. You are now ready to begin monitoring DECG: see the section "Monitoring DECG" for your next step.

## With Patient Module M1364A or M1365A

To monitor fetal DECG using the DECG Adapter Cable M1362B and either an ECG-only patient module (M1364A) or an FSpO<sub>2</sub>/ECG combined patient module (M1365A), follow these instructions.

1. Attach a pre-gelled electrode (M1349A) to the DECG Adapter Cable (M1362B).

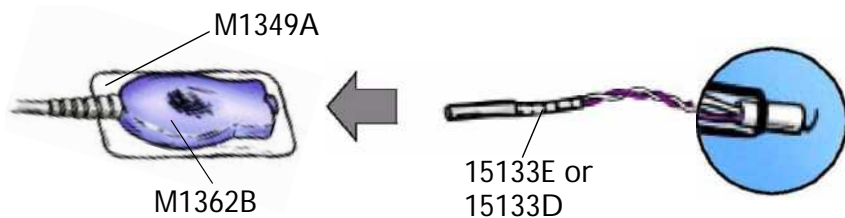

2. Connect the Fetal Scalp Electrode (15133E/15133D) to the DECG Adapter Cable (M1362B).
3. Peel the backing from the electrode (M1349A) and affix it to the mother's thigh. A good contact between the electrode and the mother's skin will improve the FHR signal. To get the best signal, ensure that the skin is clean and dry before attaching the electrode. Ensure that the electrode is correctly positioned to prevent tension in the cable from pulling on the Fetal Scalp Electrode and injuring the fetus.

4. Attach the pink connector (1) on the DECG Adapter Cable (M1362B) to the ECG pink connector (1) on the patient module (M1364A/M1365A).

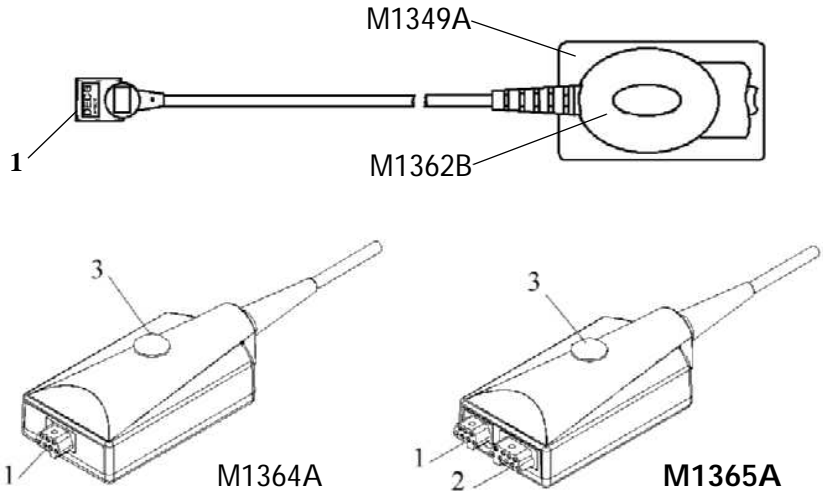

5. Fix the patient module to the patient's belt using the fixing knob (2).
6. You are now ready to begin monitoring DECG: see the section "Monitoring DECG" for your next step.

Using the DECG Adapter Cable M1362B to Monitor DECG

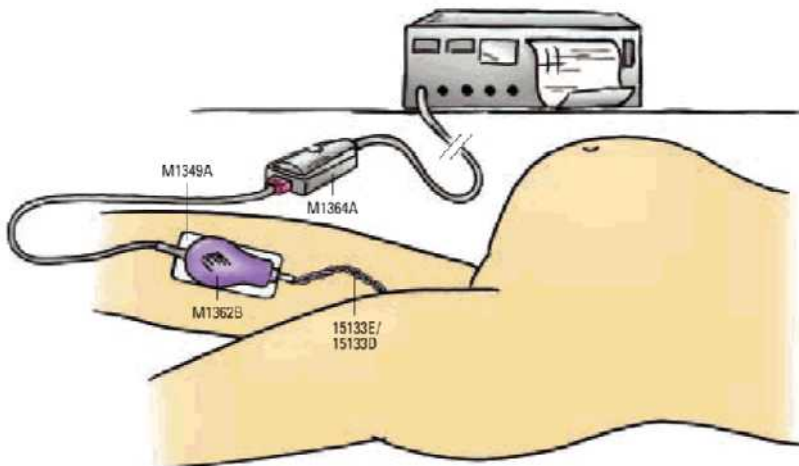

**Typical Configuration Showing Fetal Scalp Electrode 15133E/D, DECG Adapter Cable M1362B, and Patient Module M1364A**

## Monitoring DECG

1. Switch on the monitor and the recorder.
2. Connect the legplate, or patient module, to the monitor. To simultaneously measure fetal pulse oximetry and DECG you must connect the patient module to the Cardio 1/Combi socket. If you are measuring DECG only you may use either the Cardio 1/Combi socket or the Cardio 2 socket.

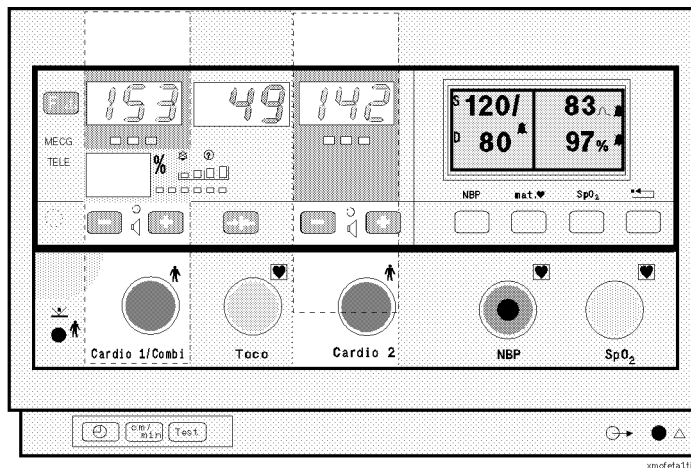

3. Check the arrhythmia logic setting. A red Signal Quality Indicator indicates logic is OFF. Green indicates logic is ON. You can change the setting by pressing **F.▲** until the monitor displays LOG. Use **+** and **-** to change the color of the signal quality indicator. You must have a DECG transducer connected to either Cardio 1/Combi socket or the Cardio 2 socket.

---

**Warning**

**Periodically compare the mother's pulse with the signal coming from the monitor's loudspeaker to ensure that you are monitoring fetal heart rate. Do not mistake a high maternal heart rate for FHR. When you monitor maternal heart rate simultaneously with FHR, cross-channel verification alerting warns you if maternal and fetal heart rates coincide.**

---

---

**Why use Arrhythmia Logic?**

When arrhythmia logic is on, instantaneous heart rate changes of 28 bpm or more are not recorded. Recording resumes when successive beats again fall within predetermined limits. This avoids recording artifacts but does not show genuine arrhythmia. When logic is off, all recorded fetal heartbeats are shown. If you suspect fetal arrhythmia, switch logic OFF. Unless you suspect fetal arrhythmia, we recommend that you use the default setting, with logic on, as this makes the trace easier to read and interpret.

---

**After Monitoring**

Turn the spiral electrode counter-clockwise to remove it, either with the presenting part crowning and the application site visible, or after delivery. Never pull it off or reuse it.



## Troubleshooting

Problem	Possible Causes	Solutions
Erratic trace. Erratic display.	No ECG signal. Poor contact between the reference electrode and the mother. Patient module is not securely fixed.	Use a new spiral electrode.  Attach the patient module to the patient's belt with the fixing button.
Signal quality indicator is red continuously.	Fetal arrhythmia.	Be sure that logic is off.
<b>nop</b> displayed.	Electrode leads not properly connected to cable block.	Check electrode lead connection.
	No contact or poor contact between reference electrode and mother.	Use a new spiral electrode.
	Spiral electrode detached.	Reattach the spiral electrode.
An error message is displayed.		See Chapter 19, "Troubleshooting."
If you suspect the signal from the transducer.		Carry out the Parameter Test as described on page 152.
If you suspect the recorder or display.		Carry out the Quick Test as described on page 151.

---

## Heart Rate Out of Limits

A questionable heart rate is rare but these are some of the possible causes.

Problem	Possible Cause
Questionable heart rate.	<b>FHR less than 30 bpm</b> FHR is not recorded and the signal quality indicator is red.
	<b>FHR between 30 and 50 bpm</b> 50-210 bpm paper records a straight line at 50 bpm. 30-240 bpm paper records the FHR.
	<b>FHR is between 210 and 240 bpm</b> 50-210 bpm paper records a straight line at 210 until 240 bpm is exceeded. 30-240 bpm paper records the FHR up to 240 bpm.
	<b>FHR exceeds 240 bpm</b> FHR is not recorded and the signal quality indicator is red.

# Monitoring Twin FHRs

---

## Introduction

You can monitor twins throughout labor and delivery after rupture of the membranes by monitoring one twin externally using ultrasound and the other internally using DECG.

If you want to monitor twins externally, you can use two ultrasound transducers, or one ultrasound transducer and a US/MECG transducer. The external method is possible only if your monitor has dual ultrasound capability.

Refer to the appropriate preceding chapters for contra-indications and other information about the measurement methods you have chosen.

---

## Things to Remember During Monitoring

When monitoring you should:

- Make sure that you are recording two different heart rates. The cross-channel verification feature alerts you if the two heart rates coincide (that is, if both transducers are recording the same FHR). If this happens, reposition an ultrasound transducer until you detect the second FHR.
- Note that the trace recorded for the Cardio 1/Combi channel is thicker (darker) than that recorded for the Cardio 2 channel. This ensures that the two heart rates are easily distinguishable.
- Remember that only one fetal heartbeat can be heard from the loudspeaker at any time. To hear the other fetal heartbeat, press either of the volume keys for the channel monitoring that fetus.

- Monitor maternal heart rate, especially during later stages of labor, to avoid mistaking maternal heart rate for FHR. Cross-channel verification then alerts you if this occurs.

---

## Monitoring Internally

Monitor one twin using the procedures described in Chapter 5, “Monitoring FHR and FMP Using Ultrasound”. Monitor the second twin using the procedures described in Chapter 6, “Monitoring FHR Using DECG”.

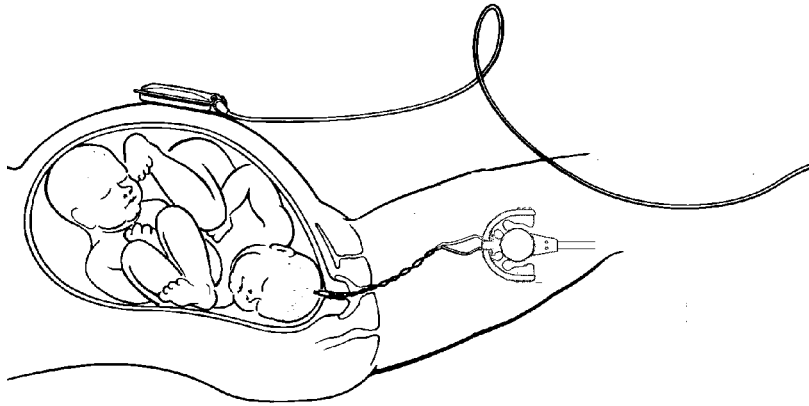

pop43fin.gif

---

## Monitoring Externally

Monitor both twins using the procedures described in Chapter 5, “Monitoring FHR and FMP Using Ultrasound”. You will need either two ultrasound transducers, or one ultrasound transducer and a US/MECG combi transducer. If you are using two US transducers, removing the white clips from both ends of one transducer will help you

to distinguish at a glance the Cardio 1/Combi US transducer from the Cardio 2 US transducer.

## Separating Twin FHR Traces

To help interpretation of traces with similar baselines, you can separate the baselines, so that one is displayed on the trace as if it is 20 bpm higher than the other. Use either the Function Key or the optional Barcode Reader to separate the traces. This feature is also known as “Twins Offset”.

### Using Keys

You must connect transducers to the Cardio 1/Combi and Cardio 2 sockets. You may use either two ultrasound transducers or a combination of one ultrasound and one DECG transducer. You cannot use two DECG transducers.

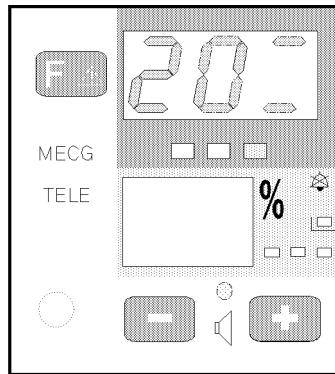

1. Press **F.▲** and release to display **20**.  
The Signal Quality Indicator shows:
  - RED if the traces are NOT SEPARATED.
  - GREEN if the traces are SEPARATED.
2. Press **-** or **+** to change the setting.
3. Press **F.▲** several times to return to the normal display.

### Using the Barcode Reader

Enter “Twins Offset” from the barcode sheet.

### Twins Offset: On

To indicate that Twins Offset is switched on and the Cardio 1/Combi trace is offset:

- A dotted line labeled '+20' prints across the FHR scale.
- The Cardio 1/Combi trace is labeled '+20' every 5cm. The following trace shows Twins Offset switched on.

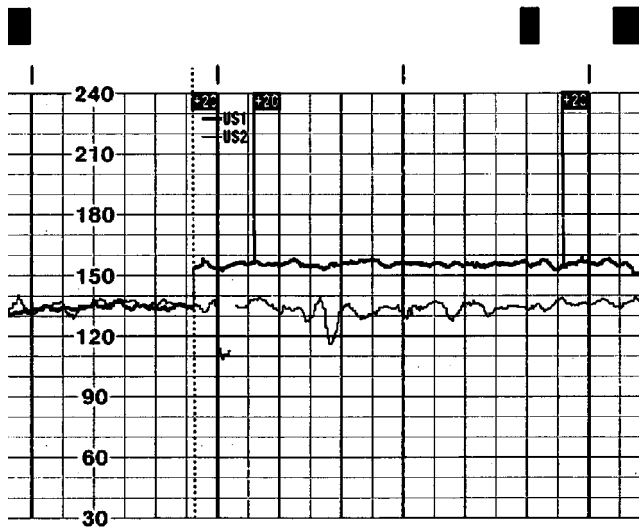

Only the trace from the Cardio 1/Combi transducer is offset. The numerical FHR value displayed on the monitor remains unchanged. The Cardio 2 trace and display do not change. Subtract 20 from the Cardio 1/Combi recorded trace to calculate the true FHR. For example, if the recorded trace shows 160 then the true FHR is 140.

If you disconnect the Cardio 2 transducer, the Cardio 1/Combi trace returns to normal. But if you later reconnect the Cardio 2 transducer, the Cardio 1/Combi trace is automatically offset again.

### Twins Offset: Off

To indicate that Twins Offset is switched off a dotted line labeled “+0” prints across the FHR scale.

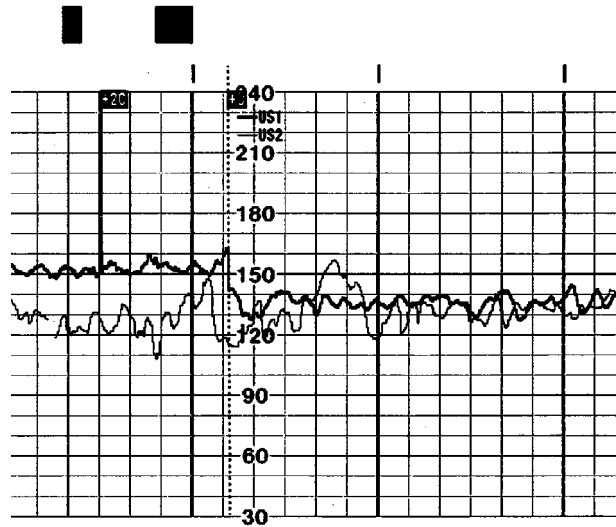

Switching off the monitor automatically switches off Twins Offset.

---

## Troubleshooting

The following problem may occur when monitoring twins.

Problem	Possible Cause	Solution
❓ is printed repeatedly.	Both transducers are recording the same FHR.	Reposition an ultrasound transducer.





# Monitoring Uterine Activity

## Introduction

You can measure uterine activity externally using a Toco transducer, or internally using an intrauterine catheter. A Toco transducer measures the frequency and duration of contractions but not their intensity. Amplitude and sensitivity depend on various factors such as the position of the transducer, the belt tension and the size of the patient. To obtain an absolute measurement, you must monitor intrauterine pressure.

## External Toco Monitoring

1. Fasten the abdominal transducer belt around the patient.
2. Connect the Toco transducer to the Toco socket on the monitor.

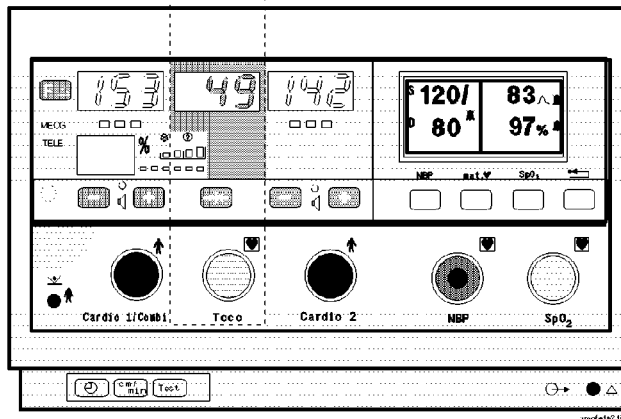

3. The Toco display shows 20. “Toco ext”, indicating external uterine measurement, is printed on the trace intermittently.

4. Place the transducer on the patient's fundus to ensure the optimum recording of uterine activity.
5. When you have a good signal, clip the transducer in position on the belt.
6. Between contractions, press the Toco Baseline Key . This zeroes the display and trace to 20.

The following example trace shows two contractions.

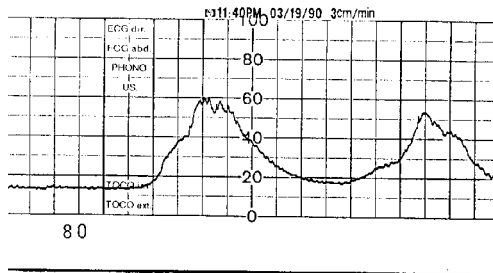

---

## Internal Toco Monitoring (IUP Monitoring)

You can monitor intrauterine pressure (IUP) using either a reusable or a disposable intrauterine catheter. Each catheter comes with its own detailed user instructions. Read the instructions that come with your intrauterine catheter before you start monitoring. Ensure that you zero the monitor when instructed.

Perform a complete clinical evaluation. Catheterize after membrane rupture. Do not catheterize if placenta previa is diagnosed or if uterine bleeding from an undetermined source is present.

1. Insert the catheter according to its accompanying instructions.
2. Connect the catheter to the monitor's Toco socket. Some catheters link to a cable that connects to the monitor. The Toco display

shows 0. “Toco int”, indicating internal measurement, is printed intermittently on the trace.

3. Zero the monitor by pressing the Toco Baseline Key . This zeroes the display and trace to 0. If you do not zero the monitor properly, the pressure trace may exceed the paper scaling. To correct this, ensure that the transducer is level with the maternal xiphoid (lower end of the sternum), then zero the monitor.
4. Flush periodically during monitoring. A pressure spike appears on the trace if you flush after connecting the transducer to the monitor.

---

## Troubleshooting

### External Toco

Problem	Possible Causes	Solutions
Quality of the trace deteriorates or the Toco baseline varies.	The belt is incorrectly fastened and is too slack or too tight or the belt has lost its elasticity.	The belt must be tight enough to ensure good contact between the patient's skin and the entire surface of the transducer without causing discomfort. Ensure you are using the correct Philips belt. Adjust it as necessary.
	Maternal movement.	Relax the patient.
	Fetal movement.	None.
	Maternal respiration superimposed on trace.	Check belt is not too loose.
Toco sensitivity is too high (above 100 units).	Physical transmission of pressure from the uterus to the sensor is much higher than the average value.	Ensure a good contact between the patient's skin and the entire surface of the transducer. Reposition transducer if necessary.
An error message is displayed.		See Chapter 19, “Troubleshooting.”
If you suspect the signal from the transducer.		Carry out the Parameter Test as described on page 152.
If you suspect the recorder or display.		Carry out the Quick Test as described on page 151.

## Internal Toco

Problem	Possible Causes	Solutions
No trace.	Catheter blocked.	Flush with sterile solution.
No change in pressure during contraction.	Dry environment or possible extra-ovular placement of sensor tip.	Flush with sterile solution or reposition sensor.
Only pressure peaks can be seen (baseline not visible).	Zero adjustment is incorrect.	Zero the system.
"-" indicator flashes.		
Trace is a straight line.	Transducer is defective.	Remove and touch the catheter. If the trace does not show up and down movements, use a new transducer.
Trace is superimposed with noise.	End of catheter is in the uterine wall or dry column.	Retract the catheter a little and flush.
An error message is displayed.		See Chapter 19, "Troubleshooting."
If you suspect the signal from the transducer.		Carry out the Parameter Test as described on page 152.
If you suspect the recorder or display.		Carry out the Quick Test as described on page 151.

# Fetal Pulse Oximetry

---

## Introduction

Fetal pulse oximetry (FSpO<sub>2</sub>) gives you a continuous real-time measurement of the percentage of oxygen saturation in the fetal arterial blood. Identifying adequately oxygenated fetuses and those at risk of hypoxia may help clarify whether or not intervention in the case of a non-reassuring fetal heart rate trace is necessary.

The FSpO<sub>2</sub> parameter is built into the Series 50 XMO (M1350C) fetal/maternal monitor. You can upgrade the following monitors to incorporate FSpO<sub>2</sub>:

- Series 50 XM (M1350B) fetal/maternal monitor.
- Series 50 IX (M1350A) fetal monitor.

This parameter is NOT available for monitors purchased in the USA.

---

## Before You Start

Read the accompanying Sensor Placement Guide carefully. It contains full details about how to place the sensor, and any contra-indications. Only clinical professionals trained in the use of sensor placement may place a fetal oxygen sensor. Use only Nellcor-approved FS14 fetal sensors.

Unlike other fetal measurements, where you get an almost instant display on the monitor as soon as you apply a transducer correctly, the FSpO<sub>2</sub> measurement can take several minutes after the sensor is correctly placed before you see a value displayed on the monitor.

---

## To Begin Monitoring

1. Plug the FSpO<sub>2</sub>/ECG combined patient module into the Cardio 1/Combi socket. The monitor displays the symbol:

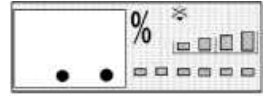

2. Check, and if necessary change, the alarm settings.
3. Connect the sensor to the patient module, maintaining sterility by exposing only the connector when you open the sensor package. The connector is color coded blue to ensure that you connect to the blue FSpO<sub>2</sub> connector, not the pink ECG input.

4. Make sure that you can see red light coming from the emitter on the sensor body. If there is no light, use a new sensor. The monitor displays the sensor lifted symbol:

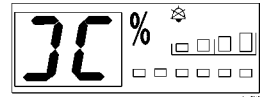

5. Apply the sensor to the side of the fetal face closest to the maternal spine, according to the instructions in the sensor placement guide. Adjust the sensor until you get skin contact. When you have contact, the monitor displays the pulse search symbol and the pulse bar lights rhythmically as the monitor searches for a signal of sufficient quality to allow it to determine the saturation value.

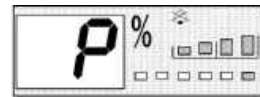

6. Wait until the four-step signal quality indicator shows that it is receiving a medium or good signal (with three or four segments lit). It may take up to a minute after this until the monitor displays the fetal oxygen saturation value. Do not reposition the sensor unless you are certain the monitor is not receiving a signal of acceptable quality.

## Understanding the Display

The following diagram shows the elements of the FSpO<sub>2</sub> display:

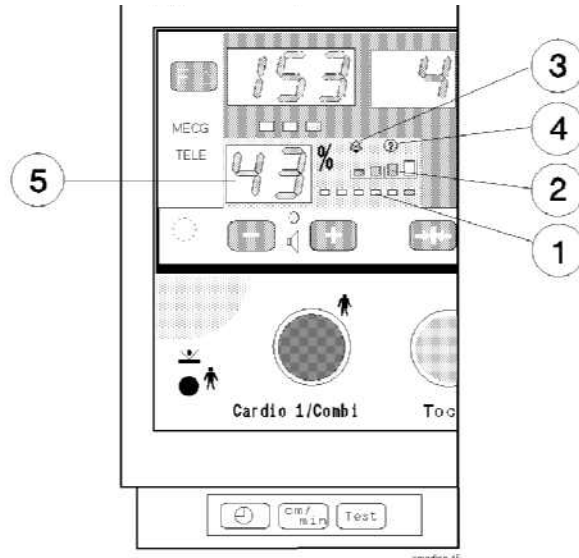

### 1. Pulse indicator

The six segments pulse rhythmically in conjunction with the fetal pulse rate when the pulsatile activity is of acceptable quality.

If the indicator pulses regularly but the monitor does not display a fetal oxygen saturation value, wait before you reposition the sensor.

The monitor may not yet be able to calculate a saturation value from the signal it is receiving.

If the pulse indicator becomes briefly irregular, and then returns to a regular rhythm, do not reposition the sensor. The irregularity is probably caused by fetal or maternal movement.

**2. Signal quality indicator**

Shortly after the pulse indicator moves rhythmically, the four-segment signal quality indicator illuminates to show how good a signal the monitor is receiving from the sensor. The more segments that light, the better the quality of the signal. Typically, the monitor needs a medium to good quality signal (with three or four lit segments) for up to a minute to calculate and then display the saturation value.

**3. Alarm status indicator**

When the crossed bell symbol is lit, alarming is switched off. When it is not lit, alarming is switched on.

**4. Cross-Channel Verification Plus (CCV+) indicator**

The fetal pulse rate from FSpO<sub>2</sub> is determined internally by the monitor. It is not displayed, on either the trace or monitor.

To warn you if you accidentally record maternal SpO<sub>2</sub> instead of fetal SpO<sub>2</sub>, (because the sensor is facing the uterine wall instead of the fetus) the monitor compares the heartrate it derives from DECG on the Cardio 1/Combi channel, (or from US on the Cardio 2 channel if DECG is not in use) with the pulse rate it derives from FSpO<sub>2</sub>. The CCV+ indicator illuminates and  is printed on the trace if the monitor:

- records a pulse rate from FSpO<sub>2</sub> and a heart rate from DECG or ultrasound that do not match for more than one minute.
- records more than 80% fetal saturation for more than one minute.



You should check the fetus and adjust the sensor until you are sure you are recording fetal oxygen saturation.

#### 5. Saturation value

This displays the level of oxygen saturation in the fetal blood.

Typical fetal values lie within the range 40% to 70%.

See Chapter 3, “General Information” on page 19 for a sample trace including FSpO<sub>2</sub>.

---

## Alarm

The monitor makes a “beeping” noise and the saturation display flashes.

### Alarm Limits

FSpO<sub>2</sub> has two alarm criteria, which you can change only when a patient module is connected to the monitor. If you change an alarm limit, your change is retained by the monitor, even if you switch the power off. The alarm limits are:

- **Saturation alarm level**

The alarm triggers if the percentage of fetal oxygen saturation falls below this point. The default setting is 30%.

- **Time delay**

This is the length of time for which fetal oxygen saturation must be at or below the saturation limit before the alarm triggers. The default setting is one minute.

When you change the monitor’s battery, the alarm settings return to the factory settings.

## Triggering an Alarm



For an alarm to trigger:

- The FSpO<sub>2</sub> alarm must be switched on **and**
- The percentage saturation must fall below the *saturation alarm level* for the length of time specified by the *time delay*.





## Acknowledging an Alarm





Press the acknowledge key on the recorder or the yellow key on the maternal display to acknowledge an FSpO<sub>2</sub> alarm.

## Turning the Alarm On and Off

1. Connect the ECG/FSpO<sub>2</sub> patient module to the Cardio 1/Combi socket.
2. Press  until the FSpO<sub>2</sub> display shows **AL** .
3. Press  to toggle between alarming on and off. The signal quality indicator for the Cardio1/Combi channel is red when alarming is OFF and green when it is ON.
4. Press  to return to normal monitor function. A crossed bell symbol, near the FSpO<sub>2</sub> display, illuminates when the alarm is off.

## Changing Alarm Limits

1. Connect the ECG/FSpO<sub>2</sub> patient module to the Cardio 1/Combi socket.
2. Press  until the FSpO<sub>2</sub> display shows **AL** .
3. Press  to access the saturation alarm limit setting. The Toco display shows **--R** , indicating that you are changing the saturation low alarm limit. The FSpO<sub>2</sub> display shows the current low limit. There is no high limit.
4. Press  or  to increase or decrease the FSpO<sub>2</sub> saturation alarm limit.

5. Press  to set the time delay. The Toco display shows ' , indicating that you are changing the time delay. The FSpO<sub>2</sub> display shows the current delay, in minutes.
6. Press  or  to increase or decrease the time delay in increments of 0.5 minutes.

Press  to return to normal monitor function.

If alarming is enabled, the alarm limits are printed on the trace. If it is disabled,  is printed.

## Inop Alarms

If the signal quality has been good for a minute or longer, and then the quality falls below an acceptable level for more than 30 seconds, the monitor beeps. This feature can be enabled or disabled through the service settings. See the Installation and Service Guide for details.

## Troubleshooting

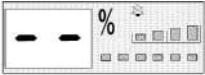
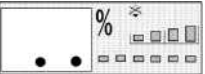
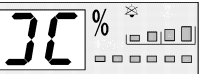
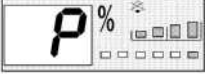
Display	Problem	Solution
	<p>Patient module not plugged in.</p>	<p>Plug in patient module.</p>
	<p>Patient module plugged in but sensor not attached.</p>	<p>Check connection of sensor to patient module. Replace patient module or sensor if necessary.</p>
	<p>Patient module and sensor are both correctly connected but no signal is obtained.</p>	<p>The sensor has lost contact with the patient. Reposition the sensor slightly.</p>
	<p>Pulse indicator bar pulses rhythmically but monitor does not display a saturation value.</p>	<p>Observe the quality indicator lights. If you do not obtain a medium to good quality signal (three or four segments lit) after waiting for at least one minute, reposition sensor.</p>

---

## Loss of Pulse Signal

Temporary loss of pulse signal is normal and the clinical professional must judge whether the trace gives enough information for diagnosis. Loss of pulse signal can occur:

- If there is excessive or prolonged fetal or maternal movement
- During uterine contractions
- If the fetus experiences shock, hypotension, severe vasoconstriction, arterial occlusion proximal to the sensor, or cardiac arrest.

---

## Inaccurate Measurements

Inaccurate measurements may be caused by:

- Incorrect placement of the sensor
- Significant levels of dysfunctional hemoglobin, such as carboxyhemoglobin or methemoglobin
- Excessive fetal or maternal movement
- Uterine contractions
- Venous pulsation
- Side effects from some drugs.



# Monitoring Using External Devices

---

## Introduction

This chapter describes how to record maternal non-invasive blood pressure (NIBP), maternal blood oxygen saturation level (SpO<sub>2</sub>), maternal temperature and maternal heart rate (MHR) by connecting a supported external device to your monitor. If you have a Series 50 XM you can connect an Nellcor OxiFirst™ Pulse Oximeter (N-400) or compatible fetal pulse oximeter.

## Recording From an External Device

If you connect an external device that replicates parameters already installed in your monitor (such as MHR, maternal SpO<sub>2</sub>, NIBP and FSpO<sub>2</sub>), the external device is ignored.

You can connect:

Supported External Devices	Parameters				
	Maternal				Fetal
	NIBP	SpO <sub>2</sub>	Temp	MHR <sup>1</sup>	FSpO <sub>2</sub>
Philips M1165A/1166A/1175A/ 1176A/1167A/1177A CMS	Yes <sup>2</sup>	Yes <sup>2</sup>	Yes <sup>2</sup>	Yes <sup>2</sup>	No
Philips 78352C/78354C Compact Configurable Monitor (CCM)	Yes <sup>2</sup>	Yes <sup>2</sup>	Yes <sup>2</sup>	Yes <sup>2</sup>	No
Dinamap 1846/8100 NIBP Monitor	Yes	No	No	Yes	No
Press-Mate/Listmini Model BP-8800	Yes	No	No	Yes	No
Accutorr 3, 4	Yes	No	No	Yes	No
Accutorr 3SAT, 4SAT	Yes	Yes	No	Yes	No
Nellcor N-200 SpO <sub>2</sub> Monitor	No	Yes	No	Yes	No
Nellcor N-400 FSpO <sub>2</sub> Monitor	No	No	No	No	Yes

1. An MHR measurement is provided in conjunction with maternal NIBP or SpO<sub>2</sub> monitoring.

2. Only if this parameter is installed on the external device.



## What You Need

To connect a supported external device you require:

Model	Requirements	
	Option J13 <sup>1</sup>	Additional Requirement
Press-Mate/Listmini Model BP-8800 NIBP	Dual Interface Board	COLIN Interface cable (available from COLIN Corporation)
Dinamap 8100	Dual Interface Board	Model 8801 interface adapter (available from General Electric)
Others	Dual Interface Board	None

1. Includes one interface cable (M1350-61609)

## Connecting the External Devices to the Monitor

Connect a supported external device via the dual serial interface at the rear of the monitor.

---

### Caution

**Before connecting an external device to the monitor, connect the equipotential grounding point (3) to earth potential. Use the grounding cable supplied with the monitor.**

---

The Dual Serial Interface has two sockets:

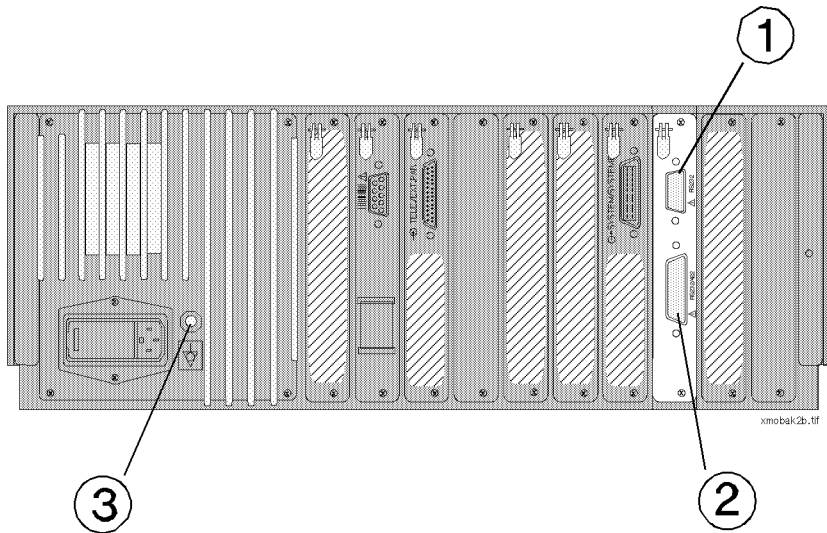

Dual Serial Interface

1. Use socket 1 (9 pin) for connecting:
  - Philips M1165A/1166A/1175A/1176A/1167A/1177A CMS.
  - Philips 78352C/78354C Compact Configurable Monitor.
  - Dinamap 1846/8100 NIBP Monitor.
  - Press-Mate/Listmini Model BP-8800.
  - Accutor 3, 4, 3SAT and 4SAT.
2. Use socket 2 (25 pin) for connecting:
  - Nellcor N-200 Maternal SpO<sub>2</sub> Monitor
  - Nellcor N-400 Fetal SpO<sub>2</sub> Monitor (M1350B only).

If you use both sockets 1 and 2, **and** maternal SpO<sub>2</sub> can be recorded from the external device connected to socket 1, the measurement from this external device has priority over the measurement from the Nellcor Monitor N-200 in socket 2.

3. Use the interface cable to connect the external device to the appropriate socket.
4. Connect the other end of the interface cable to the external device. (See the service documentation supplied with the external device for the correct socket to use for the connection.)

If you are monitoring maternal SpO<sub>2</sub> or temperature and the monitor is switched on **before** the appropriate sensor is applied, the first value documented may be incorrect as it takes up to five minutes for the correct value to be obtained.

To monitor maternal temperature on the M1165A/1166A/1175A/1176A/1167A/1177A CMS, you must connect the temperature sensor to TEMP1.

### Example Trace

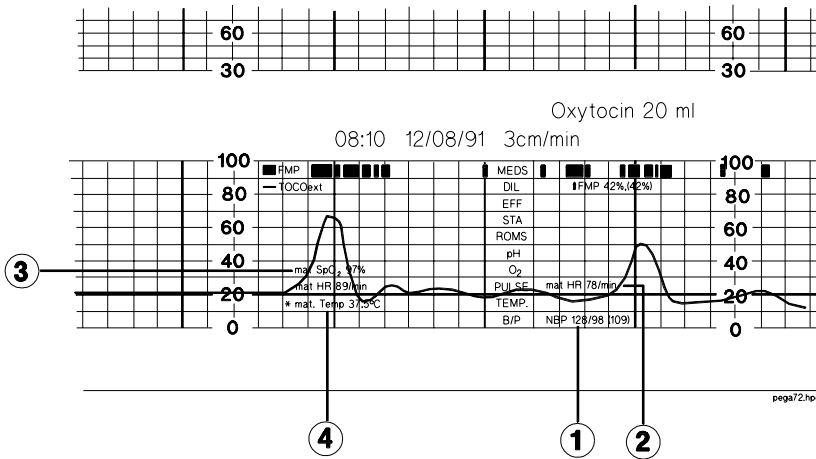

1. Maternal blood pressure:
  - Systolic blood pressure is 128 mmHg.
  - Diastolic blood pressure in 98 mmHg.
  - Mean arterial pressure is 109 mmHg.
2. Maternal heart rate (78 bpm).
3. Maternal oxygen saturation level of blood (97%).
4. Maternal temperature (37.5 °C). Note that trace annotations coming from external monitors are prefixed with an asterisk, “\*”.

#### What is printed on the trace?

External Measurement	Print on Trace
Maternal NIBP	Value at each measurement, unless in automatic mode.
Maternal SpO <sub>2</sub>	Value every 5 minutes.
Maternal temperature	Value every 5 minutes.
Fetal SpO <sub>2</sub>	Fetal SpO <sub>2</sub> trace and annotation printed on Toco scale.

If you monitor only maternal NIBP, or only SpO<sub>2</sub>, a MHR value obtained from the Philips Series 50 monitor is also automatically printed.

**Automatic  
NIBP  
Measurement**

If you are using automatic mode with a short repetition interval, not all measurements can be recorded on the trace. The speed at which the paper moves through the recorder determines when measurements are printed.

Paper Speed	Measurement Notation
1 cm/min	Every 3 minutes
2 cm/min	Every 2 minutes
3 cm/min	Every 1 minute

---

## Trace Display on External Monitoring Systems

The trace displayed on a connected monitoring system, such as OB TraceVue, or retrieved from one, may not be identical to the recorder trace. The following details may not be shown on the system:

- Notes annotated on the paper using the Barcode Reader.
- Fetal Movement Profile.
- Separated twin FHR traces (when the Cardio 1 Combi trace is offset by 20 bpm).
- Maternal parameters.

Cross-channel verification (detecting when two heart rates coincide) is transmitted to OB **TraceVue**.

---

## Troubleshooting

### FSpO<sub>2</sub>

If the external Nellcor N-400 FSpO<sub>2</sub> monitor has two power switches (a mains switch at the rear of the unit and a standby switch at the front of the unit), take care to switch them on and off in the correct order, as shown below. If you do not, the unit can appear to malfunction by displaying data erratically, or not at all.

- To switch off the N-400 FSpO<sub>2</sub> monitor
  - Turn the front switch (on/standby) to standby
  - Turn the rear switch (mains power switch) to off.
- To switch on the N-400 FSpO<sub>2</sub> monitor
  - Turn the rear switch (mains power switch) to on
  - Turn the front switch (on/standby) to on.

If the unit malfunctions, switch it off as described above, wait for five seconds and then switch it on again.

If you use the N-400 FSpO<sub>2</sub> monitor regularly, we recommend that you keep the rear switch (mains power) in the “on” position and use the front switch (on/standby) to change from on to standby mode.

## External Devices

The following table identifies common problems and solutions you may encounter when connecting external monitoring devices.

Problem	Possible Cause	Solution
<b>General - All External Devices</b>		
No maternal measurements are printed on the trace.	Cable connected incorrectly.	Check cable connections.
	External device is not configured to the fetal monitor.	Check configuration settings on the external device. See external device service guide for details.
	Dual Serial Interface Board is not configured to the external device.	Check Interface Board settings. See the Installation and Service Manual for more information.
	Dual Serial Interface Board is not working.	Carry out the Self Test as described on page 150, and check error messages.
<b>Nellcor N-200 SpO<sub>2</sub> Monitor and OxiFirst™ Fetal Oxygen Saturation Monitor (N-400)</b>		
No SpO <sub>2</sub> and no MHR measurements are printed on the trace.	Nellcor monitor is being powered by its internal battery. (Battery power symbol is lit.)	Switch on AC power, following the instructions in the section on Troubleshooting FSpO <sub>2</sub> on page 90. The battery power symbol should go out.
<b>Philips M165A/M1675A/M1676A/M1167A/M1177A</b>		
No maternal measurements are printed on the trace.	The parameters are switched off.	Switch on the parameters in the Parameters On/Off menu. See the Component Monitoring System <i>User's Reference Guide</i> .
	Wrong interface cable.	Ensure the interface cable M1350-61609 is used. (The number is printed on the cable.)
No MHR measurement is printed on the trace.	Incorrect parameter source.	If the SpO <sub>2</sub> /PLETH module is plugged in, then set the HR/PULSE source to PLETH.
No maternal temperature is printed on the trace.	TEMP1 is not labeled T1.	Change TEMP1 label to T1.
	Temperature sensor is not connected to module TEMP1.	Check cable connection of temperature sensor.





# 11

## Recording Notes

---

### Introduction

The optional barcode reader and sheets of barcodes let you record your most commonly-used notes, and some patient information on the trace.

---

### Recording A Note

To record a note on the trace:

1. Switch on the recorder.
2. Hold the reader pen as you would a normal pen.
3. Place the tip of the pen in the white margin on one side of the barcode.

4. Using gentle pressure and constant speed, draw the pen (from right to left, or left to right) over the center of the barcode to the white margin on the other side. Do not let the pen wander from the barcode or stop before it reaches the white margin

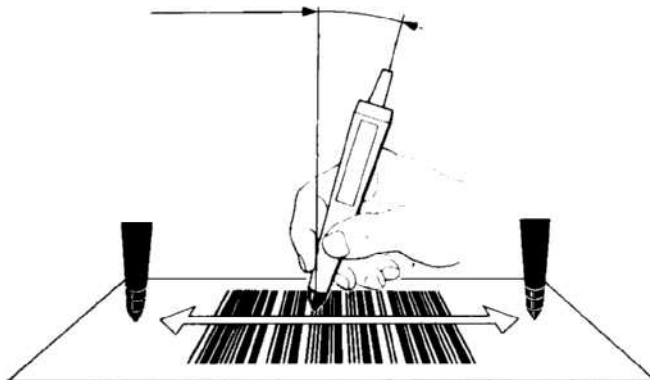

The monitor “beeps” when it receives the barcode. If there is no “beep”, you should read the barcode again.

---

## Deleting a Barcode Note

Read “CANCEL” to delete an entry. If you do not read “CANCEL” within 15 seconds, the note is entered automatically.

---

## Recording Several Barcodes as One Note

To record several barcodes as one note, read each barcode in turn and then read “ENTER”. The maximum length of a note is 30 characters. The note is printed on one line.

For example, to record a blood pressure of 150/85 as shown in the picture below:

1. Read the following codes:  
 BP:  
 1  
 5  
 0  
 /  
 8  
 5
2. Read "ENTER".

---

## Recording Several Barcodes as Separate Notes

To record several barcodes as separate notes:

1. Read a barcode.
2. Read "ENTER".
3. Repeat steps 1 and 2 to read all the barcodes you need. The notes appear on three lines as shown in the example below.

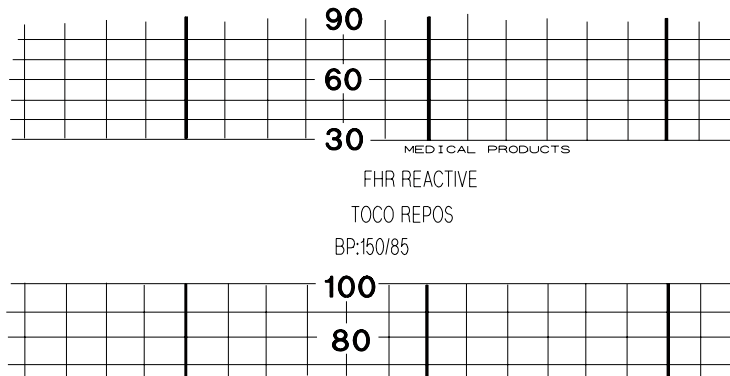

---

## Recording a Patient's Name

To record a patient's name on the paper:

1. Read each letter of the patient's first name.
2. Read "SPACE".
3. Read each letter of the patient's second name.
4. Read "ENTER".

# Fetal Heart Rate Alerting

---

## Introduction

Fetal heart rate alerting can give both audible and visual warning of a non-reassuring fetal condition. Fetal heart rate (FHR) alerting is **NOT** available for monitors purchased in the USA.

---

## Alerts

Your monitor must be enabled for alerting, via a service setting, before you can use the alert facilities.

## Recognizing an Alert

When the fetal heart rate is outside a given **High Alert Limit** (tachycardia) or **Low Alert Limit** (bradycardia) for a defined length of time (**Delay**), the monitor gives an audible alert and flashes the FHR numeric display.

FHR alerting activates after about half a minute of valid heart rate signals (green or yellow signal quality indicator). When the recorder has been switched off, the alerting is reset and another half minute of valid FHR is required to activate the alerting. This prevents the monitor giving a signal loss alert when no patient is being monitored.

## Acknowledging an Alert

Press  or **Reset**. If the FHR remains outside the given limits after you acknowledge an alert, the alert recurs after the Delay time.

### Turning Alerting ON or OFF

1. You must connect either an ultrasound or a DECG transducer to one of the two Cardio sockets.
2. Press **F.▲** repeatedly until **AL** is displayed.  
 The Signal Quality Indicator shows:
  - RED if fetal alerting is OFF.
  - GREEN if fetal alerting is ON.
 Press **-** or **+** to change this setting.

### Changing Alert Limits

1. Connect either an ultrasound or a DECG transducer to one of the two Cardio sockets.
2. Press **F.▲** repeatedly until **AL** is displayed.
3. To display the next alert limit setting press **←→**.  
 Use **-** and **+** to change the next alert setting.

Alert Setting (shown in FHR1 display)	Alert Setting (shown in Toco display)
High alert limit Default 150 bpm, 0 = off	--A
Alert delay for high limit Default 60 seconds	"-A
Low alarm limit Default 110 bpm, 0 = off	--A
Alert delay for low limit Default 60 seconds	"_A

The monitor retains these settings, even when switched off. They are printed on the recorder every few pages if alerting is on.

4. Press **F.▲** to return to the normal display or wait 15 seconds for the data to be automatically entered.

# Non Stress Test Timer



---

## Introduction

This chapter explains how to set the non stress test (NST) timer.

---

## Setting the NST Timer

1. Ensure the recorder is off.
2. Press the recorder ON/OFF key  for 2 seconds.
3. Adjust the timer using the  and  keys. The setting is displayed for 15 seconds and the timer starts. An egg timer symbol is printed on the paper to indicate that the NST timer is activated.

To switch the timer off, select a setting of 0.

After the selected time has passed:

1. A 10 second audible tone sounds (optional).
2. The recorder stops (optional).
3. The paper advances to the next perforation.

Optional settings for the NST timer are enabled via a service setting and are listed in the Installation and Service Guide for your monitor.





# Maternal Monitoring - Overview

---

## Introduction

This chapter gives an overview of the following maternal parameters:

- Maternal blood pressure
- Maternal heart rate
- Maternal pulse oximetry

## Maternal Parameters - Overview

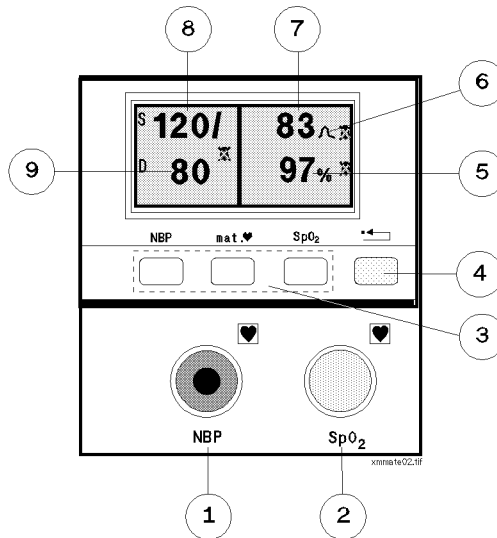

1. Non-invasive blood pressure transducer socket.
2. Pulse oximetry transducer socket.
3. **Softkeys** for setting maternal parameters. They are:
  - NBP softkey selects the mode and alarm limits for non-invasive blood pressure.
  - MHR softkey selects the alarm limits for maternal heart rate and MECC waveform.
  - SpO<sub>2</sub> softkey selects the alarm limits for pulse oximetry.
4. Reset key returns monitor from setting mode to maternal parameter display. Also used to acknowledge an alarm.
5. SpO<sub>2</sub> value indicates the current reading for patient's SpO<sub>2</sub> level.
6. **MHR icon** indicates source of MHR. The signals are sorted by accuracy, with the most accurate heart rate value shown first:

 indicates heart rate value taken from MECC measurement.

 indicates pulse rate value taken from SpO<sub>2</sub> measurement.



indicates average heart rate value taken from NIBP measurement.

7. **Maternal heart rate** shows current heart rate or pulse rate in beats per minute.
8. **Systolic value** shows the value for the systolic parameter of the most recent non-invasive blood pressure measurement.
9. **Diastolic value** shows the value for the diastolic parameter of the most recent non-invasive blood pressure measurement.

## Softkeys

A softkey is a key whose function varies according to the task you are performing. When a choice is highlighted on the maternal screen display, pressing the softkey immediately beneath this selects it.

## Reset Key

The reset key is yellow for easy identification. It has several functions:

- **One short press**  
Acknowledges warning message or  
Acknowledges alarm or  
Redisplays maternal main screen.
- **One press, held for two seconds**  
Accesses volume and contrast setup screen.
- **Two presses within one second**  
Displays current maternal alarm limits.

These functions are available only when the display shows the maternal main screen (see page 104).

---

## Power on Screen

When you first switch on, the monitor displays its power on screen, with factory set default alarm limits.

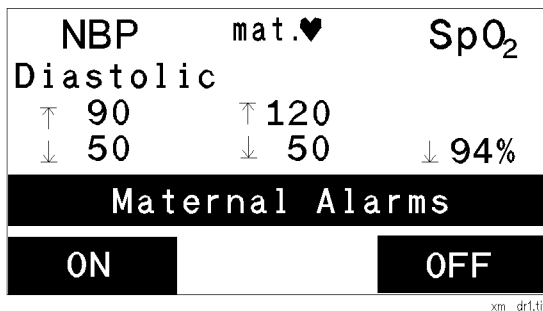

---

## To Begin Monitoring Immediately

- Step 1.** Switch the monitor on.
- Step 2.** Apply the blood pressure cuff, MECG transducer and SpO<sub>2</sub> transducer to the patient as required.
- Step 3.** Press ON to turn all maternal alarms on simultaneously with their factory set default limits or OFF to turn all maternal alarms off simultaneously.

The monitor displays the maternal main screen. You will find out how to change and set the alarm limits later in this guide.

---

## Maternal Main Screen

The screen that you will view most often is the maternal main screen. When the monitor is displaying this screen, you can view all the maternal vital signs at a glance, see which parameter alarms are on, and which

parameters (if any) are currently in an alarm condition.

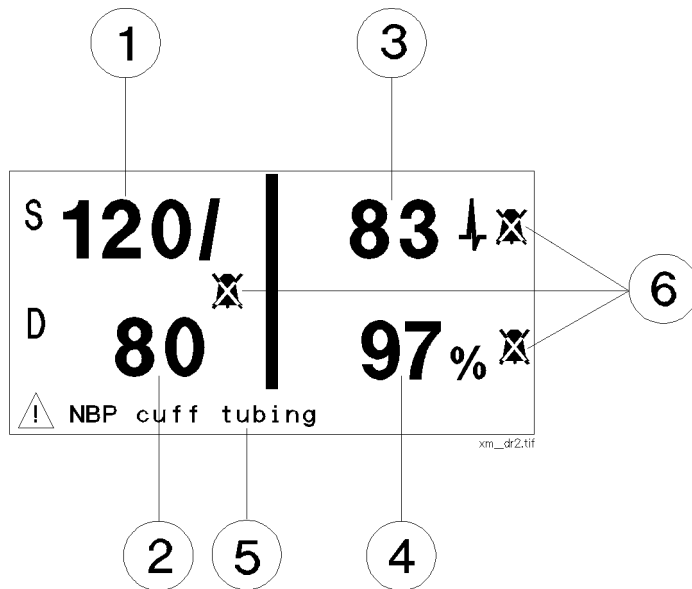

### Maternal Main Screen

1. Systolic blood pressure.
2. Diastolic blood pressure.
3. Maternal heart rate (if derived from MEEG) or pulse rate (if derived from pulse oximetry).
4. Current oxygen saturation (SpO<sub>2</sub>) level.
5. Warning messages (if any).
6. Alarm status for maternal parameters. The alarms shown in this example are **OFF**. When alarms are on, no crossed bell icon is shown.

---

## Returning to the Maternal Main Screen

When you are working with the maternal measurements, individual screens replace the maternal main screen. If you need to view the maternal main screen quickly, press the reset key once. The monitor automatically redisplay this screen if there is an interval of approximately 20 seconds between key presses while you are changing any alarm, volume or contrast setting.

---

## Alarms - Overview

Here are some of the main features of the maternal alarms:

- Each maternal parameter has an alarm that you can both hear and see.
- You choose which maternal alarms to have on or off.
- When an alarm is off the monitor displays a crossed alarm bell icon for that parameter on the maternal main screen.
- You can change the alarm limits to suit each patient.
- The power on alarm limits for alarms are preset at the factory.

The monitor beeps and highlights the alarm parameter with a flashing dark background on the maternal main screen. If the alarm parameter returns to a satisfactory value before you acknowledge it, the alarm stops automatically. Both the beep and the flashing background return to normal.

### Acknowledging an Alarm

Acknowledge an alarm by pressing the reset key or the event marker key once. The audible alarm ceases. After acknowledgement if the parameter continues to be over the limit, the highlight remains on the screen.

### Reviewing All Alarm Settings

To look at all current alarm settings at one glance, redisplay the power on screen by pressing the reset key twice within one second.

## Setting an Alarm

You can find out how to change each maternal alarm in the section relevant to that parameter. When you change alarm settings for an individual patient, the monitor automatically updates the power on screen with the new values. If the monitor's power is switched off for less than one minute, the monitor remembers any alarm values you have set for a patient. However, if the power is off for more than one to two minutes, the default alarm limits become active when power is restored.

---

## Warning Messages

In some circumstances, such as when the patient is moving excessively, the monitor may have difficulty making measurements. This is not an alarm condition so the monitor does not beep. However, it displays a warning message at the bottom of the maternal main screen.

---

## Acknowledging a Warning Message

Press the reset key once to acknowledge a warning message. When you have rectified the problem, you can continue to make measurements. Warning messages for individual maternal parameters are discussed at the end of the appropriate chapter.

## Volume and Contrast Control

You can increase, or decrease, the volume of the alarms and the contrast of the display screen. The method is exactly the same for both.

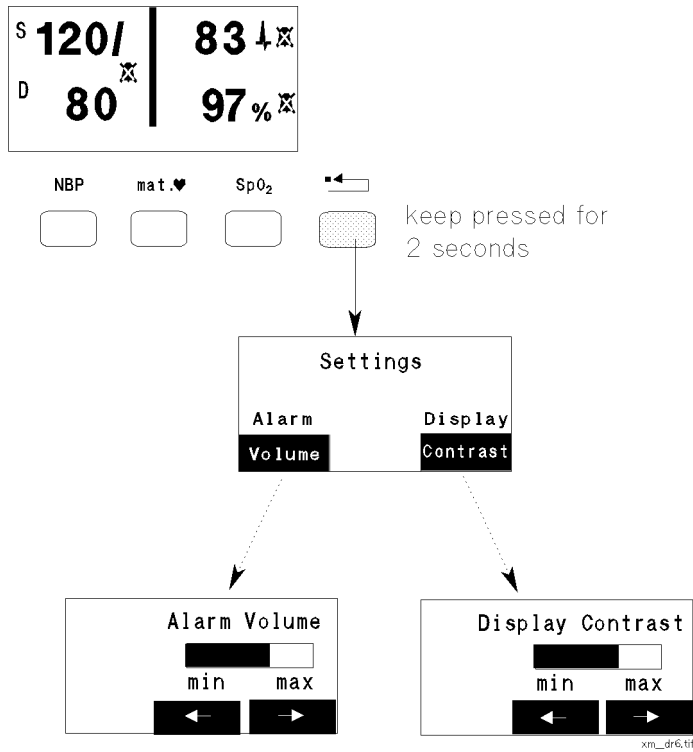

Volume and Contrast Control

- Step 1.** Display the maternal main screen.
- Step 2.** Press the reset key and **keep it pressed** until the settings screen replaces the maternal main screen. This takes about two seconds.
- Step 3.** Press **Volume** or **Contrast**.
  -  Press this to decrease the setting.



 Press this to increase the setting.

**Step 4.** Press the reset key to return to the maternal main screen. A single tone at the current volume accompanies each key press when you change the volume. A single click and contrast change accompanies each key press when you change the contrast. The indicator bar shows you how much further you can adjust the parameter.



# Non-invasive Blood Pressure Monitoring



---

## Introduction

When you first switch the monitor on, non-invasive blood pressure measurement is in manual mode. The maternal main screen displays **0** for both systolic and diastolic values.

---

## To Begin Monitoring

1. Ensure that the non-invasive blood pressure cuff is applied correctly to the patient and is not on the same arm as an SpO<sub>2</sub> finger transducer.
2. Connect the cuff to the interconnect tubing.
3. Plug the interconnect tubing into the monitor's NBP socket.
4. Press 
5. Press 

The monitor takes a single measurement, displaying the systolic and diastolic values on the maternal main screen. The rest of this chapter tells you how to change the measurement mode and set the alarms.

## Setup Screen

Use the non-invasive blood pressure setup screen to start measurements, change mode, and enter the alarm setup screen. Press **NBP** to access the setup screen.

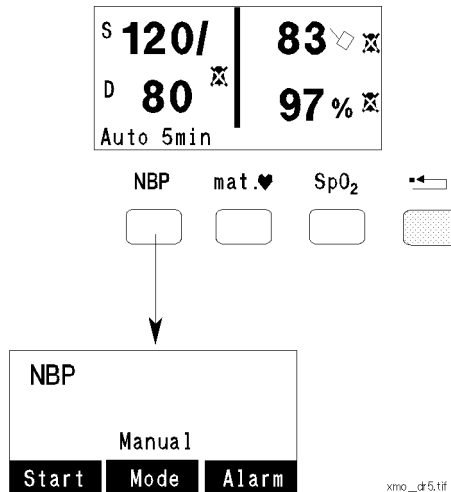

NBP Setup Screen (Manual Mode)

- Start** Press this to begin a measurement immediately. If the monitor is in stat mode, this commences a stat cycle. When a measurement is taking place, the start key is replaced by **Cancel**. Press this to cancel the current measurement, if necessary. The cuff automatically deflates.
- Mode** Press this to change between manual, auto and stat measuring modes.
- Alarm** Press this to enter Alarm Setup.

---

## Measurement Modes

Three modes of non-invasive blood pressure measurement are available:

- **Manual**  
The monitor executes a measurement on demand. This is the preferred method.
- **Automatic**  
The monitor continually repeats measurements. You can adjust the time period between measurements from two to 60 minutes.
- **Stat**  
The monitor executes a rapid series of measurements over a five minute period. Do not use stat mode unless your patient is supervised.

Unless you make a subsequent measurement, the monitor displays the most recent measurement for up to one hour.

If possible, avoid measuring during contractions because the measurement:

- May not give a reading that is truly representative of the patient's normal blood pressure.
- May cause additional stress for the patient.

## Changing Measurement Mode

To change measurement mode, press **NBP** to enter the non-invasive blood pressure setup screen.

<b>Manual</b>	<ol style="list-style-type: none"> <li>1. Press <b>Mode</b> until <b>Manual</b> is displayed above the mode key.</li> <li>2. Press <b>Start</b> to make an immediate NBP measurement</li> </ol>
<b>Auto</b>	<p>Press <b>Mode</b> until <b>Auto</b> is displayed above the mode key. A third soft key allows you to set the time interval between automatic measurements.</p> <ul style="list-style-type: none"> <li>• Press <b>Repeat</b> to cycle through the available time intervals (2, 5, 10, 15, 30 and 60 minutes).</li> <li>• Press <b>Cancel</b> to stop the current automatic measurement, and remain in automatic mode.</li> <li>• Press <b>Exit</b> to leave auto mode and return to manual mode. The <b>Exit</b> key replaces the <b>Mode</b> key after the first automatic measurement has taken place.</li> </ul>
<b>Stat</b>	<ol style="list-style-type: none"> <li>1. Press <b>Mode</b> until <b>Stat</b> is displayed above the mode key.</li> <li>2. Press <b>Start</b> to initiate a measurement cycle. Without pausing, measurements are repeated for five minutes. At the end of this time, the monitor returns to manual mode. If the power to the monitor fails during a period of stat measurement, the mode returns to manual when power is restored.</li> <li>3. Press <b>Exit</b> to leave stat mode and return to manual mode. The <b>Exit</b> key replaces the <b>Mode</b> key after the first stat measurement has taken place.</li> </ol> <p>If you press <b>Cancel</b> during a stat measurement, the measurement ceases and the monitor returns to manual mode.</p>

---

## Pulse Rate

When the monitor takes a NIBP measurement, it can also calculate the average pulse rate. This occurs in either manual or automatic mode, when neither MECG nor SpO<sub>2</sub> is being measured. The value is shown on the screen and printed on the trace. It is an average pulse rate, taken during the most recent NIBP measurement. It is not the actual value. The value is updated after each successive NIBP measurement. If you need a continuous measurement, you should monitor using MECG or maternal SpO<sub>2</sub>.

When the pulse rate is derived from NIBP the maternal display screen shows  to the right of the heart/pulse rate display. No alarming is possible.

---

## Alarms

The non-invasive blood pressure alarm sounds if the patient's blood pressure falls below, or rises above, the set limits. You can choose whether to have the alarm dependent on the systolic or diastolic measurement. You can view the current settings by displaying the power on screen.

## Turning Alarms On and Off

The following illustration shows an example alarm setting for NIBP.

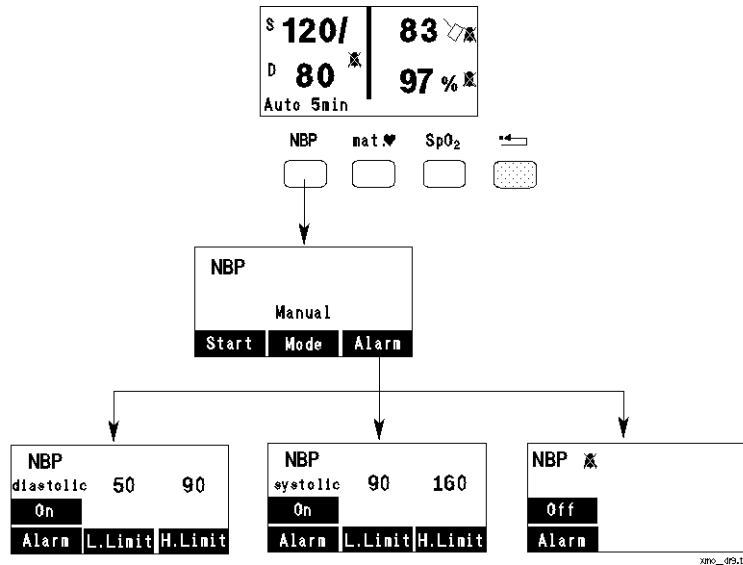

The diastolic low limit is 50, the high limit 90. The systolic low limit is 90, the high limit is 160. NBP alarming is switched off.

1. Press **NBP** to display the NBP setup screen.
2. Press **Alarm** to display the alarm setup screen.
3. Press **Alarm** repeatedly to cycle between alarm OFF and the alarm limit setting screens for systolic and diastolic values.



## Changing Alarm Limits

Starting from the maternal main screen, to change alarm limits:

1. Press **NBP** to display the NBP setting screen.
2. Press **Alarm** to display the alarm setup screen.
3. Press **Alarm** until the parameter you want to change (either systolic or diastolic) is displayed, with its current values. You cannot have both systolic and diastolic active. You must choose one or the other.

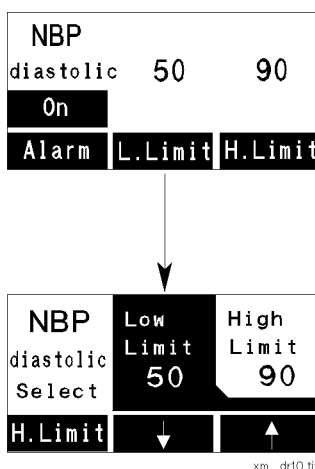

### Setting the Diastolic Low Limit

1. Choose whether you want to change the upper or lower limit. Either:
  - Press **H Limit** to select the high limit alarm. Press **↑** to increase the high limit or **↓** to decrease the high limit in steps of 5 mmHg
  - OR
  - Press **L Limit** to select the low limit alarm. Press **↑** to increase the low limit or **↓** to decrease the low limit in steps of 5 mmHg.

## Recording





Each new measurement value is recorded only if the previous value printout is finished. The printout shows the mean pressure in brackets.

---

## Troubleshooting

This section details warning messages, possible measurement problems and limitations associated with measuring non-invasive blood pressure.

### Warning Messages

Warning Message	Situation	Audible Indication	Action Required
 overpressure	Cuff pressure increases above 300mmHg.	Yes (cannot be switched off).	Check to see if cuff is being pressed manually (perhaps by patient movement) and restart the measurement. Cuff deflates automatically.
 artifacts	Patient is moving.	Yes (if alarming is on).	Restrain patient movement and restart the measurement.
 cuff tubing	Inflation/ deflation takes too long.	Yes (if alarming is on).	Check that all tubes are connected properly, not blocked, leaking or defective. Ensure that the correct cuff is being used. Restart the measurement
 NBP error	Tubing obstructed, or hardware problem.	Yes (if alarming is on).	Check tubing. Switch monitor off and try measurement again. If problem persists, call service personnel.

## Measuring Problems

Situation	Possible Cause	Possible Solution
Cuff will not inflate.	Monitor in service mode.	Switch power off, then switch on again.
	Technical defect.	Call service.
	Cuff tubing not connected.	Connect cuff tubing.
High or low values measured (against clinical expectations).	Contraction occurring.	Wait until contraction has finished.
	Patient talking before or during measurement.	Allow patient to rest quietly, then try again after 3 to 5 minutes.
	Incorrect cuff size.	Check cuff size, level and position.
	Cuff too large or not at heart level.	Check cuff size, level and position.
Displays zeros for systolic and diastolic. Measurement automatically repeats.	Severe vasoconstriction at cuff site.	Move cuff to another limb, check for shock, or verify using another method.
	Erratic blood pressure fluctuations due to arrhythmias or rapid-acting drugs or contractions.	Try again, if no success verify using another method. Wait until contraction has finished.
	Excessive patient movement or convulsions.	Restrain movement or verify using another method.
An error message is displayed.		Refer to the table of error messages for their causes and solutions
If you suspect the signal from the transducer.		Carry out the Parameter Test as described on page 152.
If you suspect the Recorder or display.		Carry out the Quick Test as described on page 151.

## Limitations

Oscillometric measurement has some limitations according to the patient's condition. The measurement looks for a regular arterial pressure pulse. If this is difficult to detect the measurement time increases and the measurement itself is unreliable.

Measurements will be:

- Impossible if the patient has an extremely **low (beneath 30) or high (above 240) heart rate**.
- Unreliable or impossible if the **patient's blood pressure is changing rapidly** over the period of time during which the arterial pressure pulses are being analyzed to obtain the measurement.
- Unreliable or impossible if the patient displays **cardiac arrhythmias** causing an irregular heart beat. The measurement time increases.
- Unreliable if the patient is in **severe shock or hypothermia**, since reduced blood flow to the peripheries reduces pulsation of the arteries.
- Unreliable if made during **uterine contractions**.

# Maternal ECG, Heart and Pulse Rate

---

## Introduction

You can monitor maternal ECG, view the waveform on the screen and print it on the trace. You can also set alarms for heart and pulse rate.

---

## To Begin Monitoring

1. Connect the transducer to the required monitor socket. See “Input Channels at a Glance” on page 25 for a list of possible transducer/socket combinations.
2. Apply the transducer to your patient.

The loudspeaker emits a click when a heart rate is being monitored. The click volume is controlled via the a service setting. The MHR trace (which is thinner than a fetal trace) prints on the paper. There is no signal quality indicator for MEECG.

## Connecting the Transducer

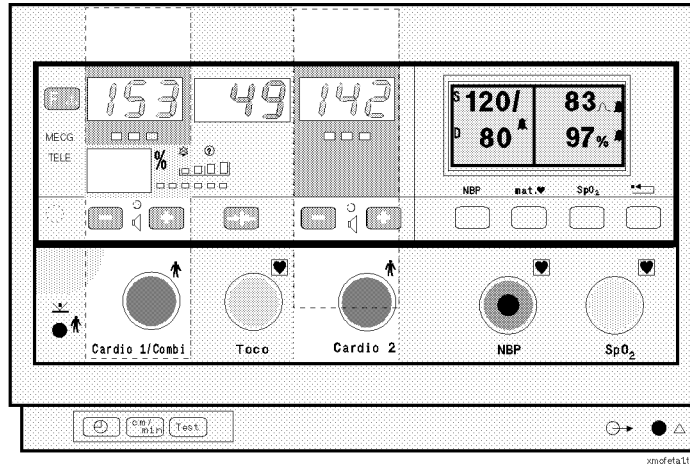

When you connect the transducer:

1. The “---” display goes out.
2. The **MECG** indicator comes on.
3. The monitoring mode (either **MECG** or **US1/MECG**) is printed on the paper immediately and then every three to four pages.

If a fetal transducer is connected to the **Cardio 1/Combi** or **Cardio 2** channel, then you can change the volume of the maternal heartbeat using the volume keys for the fetal cardio channel.

## Applying the Electrodes

To obtain a satisfactory maternal ECG waveform you **must** use the RA to LL 2-lead position of the standard 5-lead ECG.

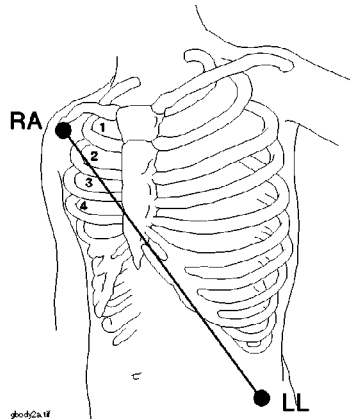

1. Place RA electrode directly below the clavicle and near the right shoulder.
2. Place LL electrode in left lower abdomen.

If you do not want to view the MEEG waveform, you can position them as shown in the following diagram. This may be more comfortable for the patient.

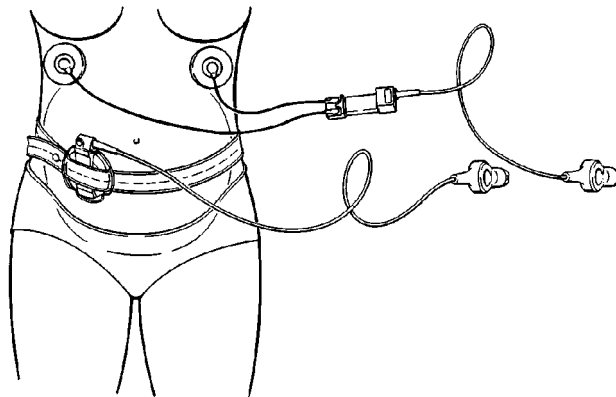

## Using MECG transducer M1359A

1. Connect each lead to an electrode and to the transducer.

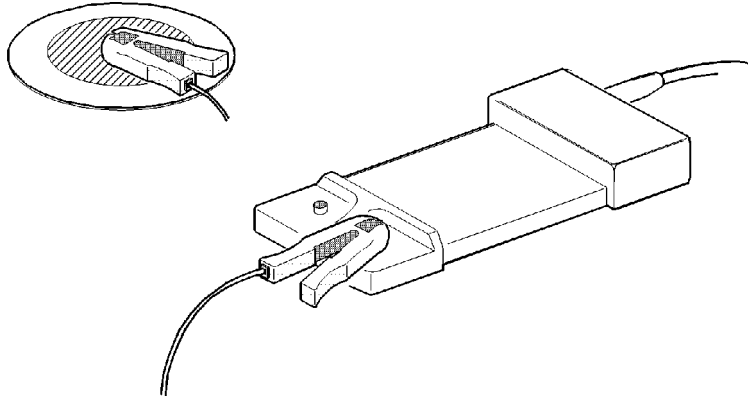

2. Peel the backing from the electrodes and apply them to the patient.
3. Slide the transducer under the belt or clip the cable to the bed sheet or patient's clothing.

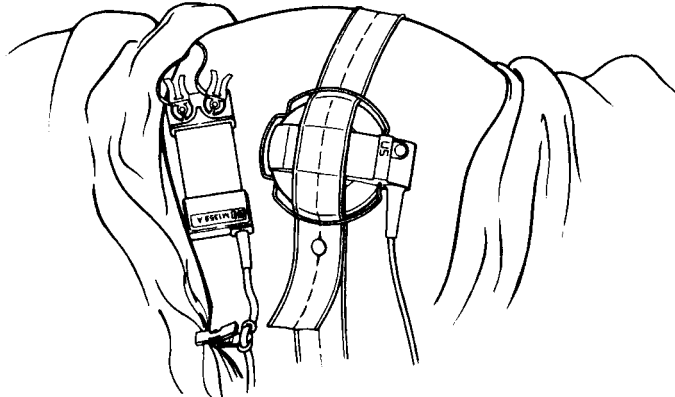



## Using a Patient Module (M1364A or M1365A)

1. Connect each lead on the MECCG adapter cable to a pre-gelled electrode (4).

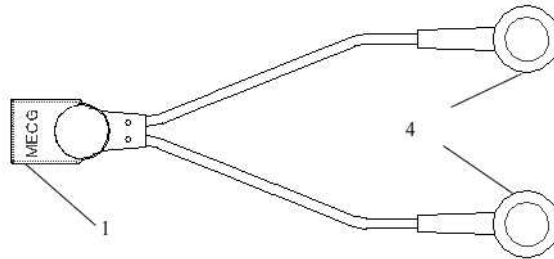

M1363A

2. Peel the backing from the electrodes and apply them to the patient.

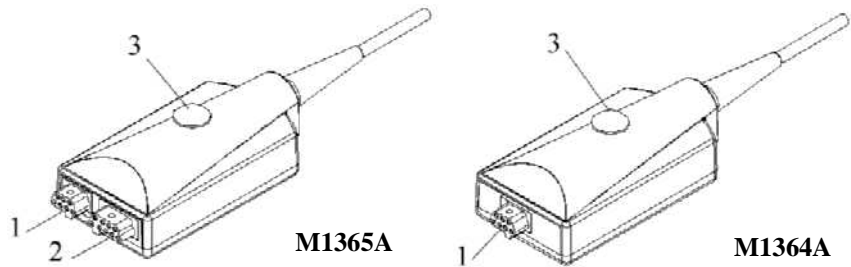

3. Connect the pink connector (1) on the MECCG adapter cable to the ECG connector (1) on the patient module.
4. Then fix the patient module to the patient's belt using the fixing knob (3).

## Cross-Channel Verification

To reduce the possibility of mistaking maternal heart rate for fetal heart rate (FHR) we recommend that you monitor both maternal and fetal heart rates, especially during the later stages of labor. If FHR and MHR coincide (that is, if the ultrasound transducer records MHR instead of FHR), the monitor's cross-channel verification facility detects this and prints  on the paper after 30 seconds.

---

## Displaying the MEEG Waveform

To display the MEEG waveform on the maternal display:

1. Press **mat** . The display changes to the MEEG Alarm/wave selection screen.
2. Press **Wave**. The display changes to the MEEG waveform.

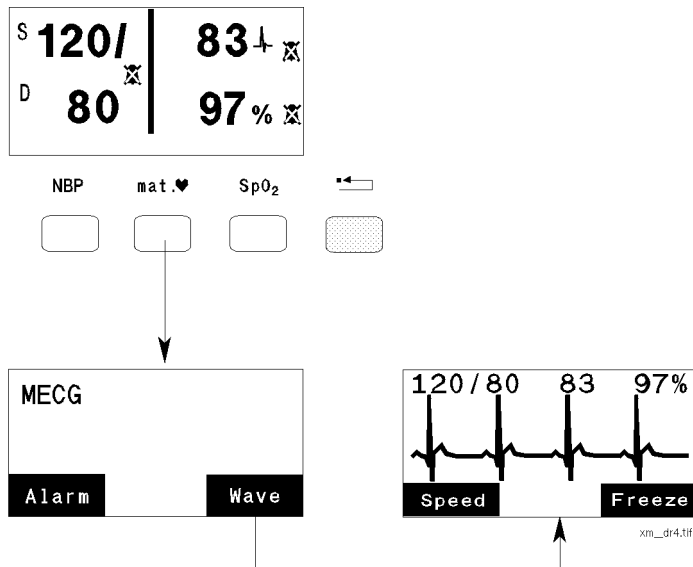

Reading from left to right, the figures at the top of the waveform show:

1. Blood pressure (systolic/diastolic)
2. Maternal heart rate (from MEEG)
3. SpO<sub>2</sub>.

Press the reset key once to return to the maternal main screen while the wave is displayed.

## Changing Display Speed

You can increase or decrease the rate at which waveforms move across the screen. Switch between slow and fast display by pressing **Speed**.

## Freezing and Printing

### Freezing the Waveform

If you want to examine the waveform more closely you can suspend its movement. Press **Freeze** to halt the display. Press **Continue** to resume the waveform display. This resumes automatically after 20 seconds if you do not press **Continue**.

### Printing the Waveform

If the recorder is on, you can print the wave onto the paper (after freezing it) by pressing **Print**. The monitor does not display the Print key if the recorder is off. The recorded waveform is a snapshot covering three to four heart beat periods. You can print wave samples during continuous fetal trace recording.

## Maternal Heartrate Source

The maternal main screen shows the maternal heart rate.

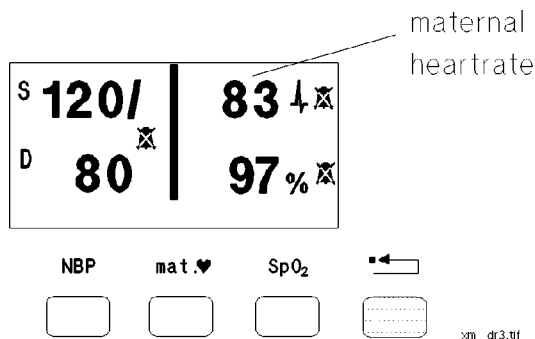

There are three possible sources for this:

- MEEG (heart rate)
- SpO<sub>2</sub> (pulse rate)
- NIBP (average pulse rate)

When the MECG transducer is plugged in, an ECG symbol  is shown to the right of the heart rate on the maternal display. If both MECG and SpO<sub>2</sub> are being monitored, the MECG heart rate value is used because it is more accurate than the pulse rate value.

If MECG is **not** being measured, but SpO<sub>2</sub> is, the pulse rate is derived from pulse oximetry. A pulse waveform symbol  is displayed on the main screen.

If **neither** MECG **nor** SpO<sub>2</sub> are being measured an averaged pulse rate from the NIBP measurement is shown. No pulse rate is shown if artifacts are present, or NIBP is used in stat mode. No alarm is possible in this mode. The NIBP symbol  is shown on the screen.

---

## Alarm (MECG and SpO<sub>2</sub>)

The maternal heart rate (MHR) alarm sounds if the MHR falls below, or rises above, the set limits. You can view the current settings by displaying the power on screen or pressing the yellow key twice. These alarm limits apply to MECG and maternal SpO<sub>2</sub> (if MECG is not being measured).

## Turning Alarms On and Off

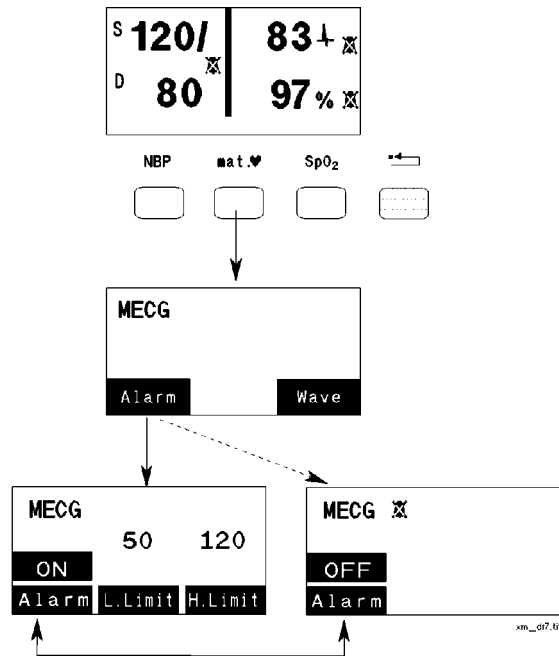

1. Press **mat** .

If the maternal heart rate is derived from SpO<sub>2</sub> measurement the alarm setup screen appears immediately. All screens show the word PULSE.

If the maternal heart rate is derived from MECG, an intermediate screen appears (as shown in the previous diagram). All screens show the letters MECG. You must press **Alarm** to display the alarm setup screen.

2. At the alarm setup screen, press **Alarm** to switch between maternal heart rate alarm on or off. When it is off, the crossed bell icon is displayed. You must switch MHR alarming on before you can change the alarm settings.



## Changing Alarm Limits

Starting from the maternal main screen, to change MHR alarm limits:



1. Press **mat**  to display the alarm setup screen.  
Remember, if heartrate is derived from MECG, the monitor displays the intermediate Alarm/Wave selection screen and you must press **Alarm** for a second time to enter the alarm setup screen.

2. Make sure **Alarm** is on.

3. Choose whether you want to change the upper or lower limit.  
Either:

Press **H Limit** to select the high limit alarm. Press  to increase the high limit or  to decrease the high limit in steps of five beats per minute.

OR

Press **L Limit** to select the low limit alarm. Press  to increase the low limit or  to decrease the low limit in steps of five beats per minute.

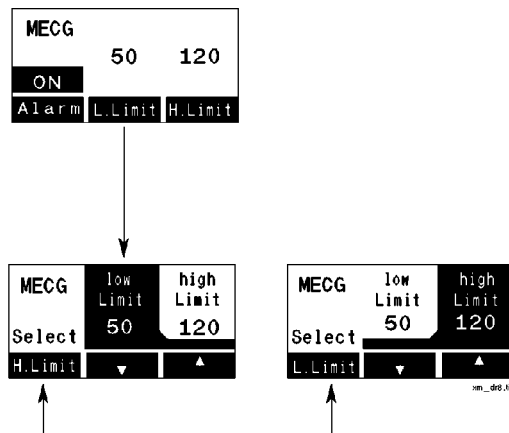

## Troubleshooting

This section details problems that might occur when measuring maternal ECG.

Situation	Possible Cause	Possible Solution
Monitor displays NOP .	Electrodes defective. Bad electrical contact.	Check electrodes and replace if necessary. Check positioning of electrodes.
 prints repeatedly	The ultrasound transducer is recording MHR.	Reposition the ultrasound transducer.
An error message is displayed.		Refer to the table of error messages for their causes and solutions.
If you suspect the signal from the transducer.		Carry out the Parameter Test as described on page 152.
If you suspect the recorder or display.		Carry out the Quick Test as described on page 151.





# Maternal Pulse Oximetry (SpO<sub>2</sub>)

---

## Introduction

When you connect a pulse oximetry (SpO<sub>2</sub>) transducer to the monitor, you can measure the percentage of oxygen saturation in the maternal blood. The monitor gives an average value calculated across four pulses. The value is recorded on the trace:

- Every five minutes
- After a no pulse condition
- Every 2.5 minutes if an alarm limit is exceeded.

If an MECCG transducer is not connected to the monitor, but you are measuring pulse oximetry, the maternal pulse rate is derived from the SpO<sub>2</sub> measurement. The pulse icon  indicates this source.

---

## To Begin Monitoring Immediately

1. Apply the maternal SpO<sub>2</sub> transducer to the patient.
2. Connect the transducer to the monitor, using an adapter cable if necessary. The monitor displays SpO<sub>2</sub> readings as soon as the sensor picks up a pulsatile signal from the patient.

## Alarm (SpO<sub>2</sub>)

The maternal SpO<sub>2</sub> alarm sounds if the SpO<sub>2</sub> level falls below the alarm value.

### Turning Alarm On and Off

1. Press **SpO<sub>2</sub>** to display the pulse oximetry setup screen.
2. Pressing **Alarm** at the alarm setting screen cycles between alarm OFF and ON.

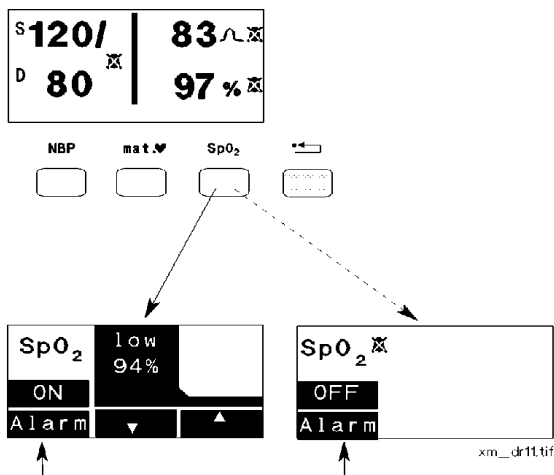

### Changing Alarm Limit

Starting from the maternal main screen, to change SpO<sub>2</sub> alarm limits, press SpO<sub>2</sub> to display the SpO<sub>2</sub> setting screen.

1. Turn **Alarm** on.
2. Press **↑** to increase the low limit or **↓** to decrease the low limit in steps of 1%. There is no high limit.

---

## Alarm (Pulse rate)

See “Alarm (MECG and SpO<sub>2</sub>)” on page 128 for how to set the pulse rate alarm.



---

## Troubleshooting

This section details warning messages, possible measurement problems and limitations associated with maternal pulse oximetry measurement.

### Warning Messages

Warning Message	Parameter Display	Audible Indication	Possible Cause	What to Do
None.	--%	No.	Transducer or adapter cable disconnected.	Connect transducer or cable.
 SpO <sub>2</sub> no pulse.	NOP.	Yes (if alarming is on).	Pulsation too weak or no pulsation detectable. Transducer incorrectly positioned.	Check patient's pulse. Reposition transducer. Ensure transducer is not on same limb as NIBP cuff.
			Patient wearing colored nail polish.	Remove nail polish.

Warning Message	Parameter Display	Audible Indication	Possible Cause	What to Do
 SpO <sub>2</sub> low signal.	Normal display.	No.	Weak signal, SpO <sub>2</sub> less accurate.	Reposition transducer or try a different site.
			Wrong transducer selected	Use correct transducer.
			Transducer incorrectly applied.	Reapply transducer.
			Photodetector not opposite light emitter.	Reposition transducer.
			Patient wearing colored nail polish.	Remove nail polish.
 SpO <sub>2</sub> light interference.	-?-	No.	A light source is so high that the SpO <sub>2</sub> transducer cannot measure SpO <sub>2</sub> or HR.	Remove strong light source, or cover transducer with opaque material.
 SpO <sub>2</sub> artifacts.	-0-	No.	Irregular pulse patterns detected, possibly arising from patient movement.	Restrain patient.

### Limitations

As with any measurement technique, there are situations that do not allow accurate pulse oximetry readings.

- If the non-invasive blood pressure cuff is on the same limb as the SpO<sub>2</sub> transducer, measurement is compromised during cuff inflation. This may result in a “no pulse” warning. If SpO<sub>2</sub> readings are unsatisfactory, check that the finger transducer is not applied to the same arm as the cuff.
- Pulse oximetry can incorrectly measure the SpO<sub>2</sub> value in the presence of:

- COHb, MetHb, and SulfHb
  - Dye dilution chemicals or other dysfunctional hemoglobins
  - Intravascular dyes
  - Venous pulsations.
- Severe reduction of pulsatile flow in the arteries can prevent accurate readings. Such a reduction can be caused by:
    - Shock
    - Hypothermia
    - Use of vasoactive drugs.



# Maintenance and Performance Assurance

---

## Preventive Maintenance

Where there are national regulations on the qualification of the testing personnel, and suitable measuring and testing facilities, these must be observed.

You must perform the following checks every 12 months to ensure that your monitor and accessories are in perfect working order.

---

### Caution

**Failure on the part of the responsible individual hospital or institution employing the use of this equipment to implement a satisfactory maintenance schedule may cause undue equipment failure and possible health hazards.**

---

## Visual Inspection

Before using any transducer, patient module, adapter cable or other accessories, you should inspect it carefully to ensure that all its components, such as the housing, cable, and connector are in good condition. If any part is broken or damaged you should not use it.

## Routine Inspection

Every 12 months, you must carry out a series of preventive maintenance tasks and performance assurance tests. These ensure that the monitor continues to perform at its best, and reduces the possibility of failures. The tasks to be carried out, their sequence, and the estimated time to complete each one is given in the following table:

Tasks and Tests
Replace the batteries.

Tasks and Tests
Carry out a mechanical inspection of the monitor.
Check transducers, cables, connectors and other accessories for cracks and defects.
Carry out the Quick Test as described on page 151.
Carry out the Parameter Test as described on page 152.

## Mechanical Inspection

To carry out a mechanical inspection of the monitor:

- Make sure all exposed screws are tight.
- Check the external cables and housings for splits, cracks or signs of twisting.
- Replace any cables that show serious damage.

---

## Calibration and Electrical Safety Checks

You must calibrate the NIBP function of your monitor every 12 months. Please refer to the Installation and Service Guide for your monitor for details.

Perform electrical safety tests as described in the Installation and Service Guide for you monitor (e.g., after repairs and upgrades).

---

## Disposal

Arrangements for the disposal of your monitor at the end of its working life should conform to your country's laws regarding the disposition of equipment containing electrical parts.



---

## Care and Cleaning

This section gives you information about how to care for and clean your monitor. Many of the supplies and accessories have their own instructions. You must refer to these for full care and cleaning information. Always follow the manufacturer's directions carefully when cleaning any equipment. Damage caused by using cleaning substances not approved by Philips is not covered under warranty.

---

### Caution

**After cleaning, disinfecting, and sterilizing the monitor and accessories, check them carefully. If you see signs of deterioration or damage, do not use the product for further measurements.**

---

---

## Care of the Fetal Monitoring System

### Monitor

Keep the outside surfaces of the monitor clean and free of dust and dirt. Do not pour liquid on the monitor or allow any to enter the monitor case. Although the monitor is chemically-resistant to most common hospital cleaners and non-caustic detergents, alternative cleaners are not recommended and may stain the monitor. Take extra care when cleaning the display surfaces; these are more sensitive to rough handling, scratches and breakage than the other external surfaces of the monitor.

Never use an abrasive material such as steel wool or metal polish.

---

### Caution

**Wipe around the NIBP connector socket, not over it, to ensure that no water or cleaning solution enters the NBP input connector.**

---

## Transducers and Patient Modules

This applies to the following transducers and patient modules:

- FSpO<sub>2</sub>/ECG combined patient module (M1365A)
- ECG patient module (M1364A)
- Ultrasound transducer (M1356A)
- DECG transducer (M1357A)
- US/MECG Combi transducer (M1358A)
- MECG transducer (M1359A)
- Toco Transducer (M1355A)

---

### **Warning**

**NEVER immerse a transducer in water when it is connected to the monitor.**

---

***Note*—The Blue Ultrasound and Toco transducers are protected against the effects of continuous immersion in water according to IEC 529 IP 68.**

### **DO NOT:**

- handle transducers roughly. This could damage the cover, piezoelectric crystals and mechanical movement. Transducer covers are made of soft plastic; avoid contact with hard or sharp objects.
- flex the cables excessively.
- allow cleaning solutions or transducers to exceed a temperature of 45°C (113°F).
- autoclave the transducers and cables or heat them above 70°C (158°F).
- permit the blue Toco transducer's ventilated cable connector to become wet as liquid can enter the ventilation tube through capillary action.

## Adapter Cables

Clean with lint free cloth, moistened with either warm water (40°C/ 104°F maximum) and soap, a diluted non-caustic detergent or one of the approved cleaning agents listed below. Never immerse or soak the cables. Do not allow the cleaning agent to remain on the cable - remove it immediately by wiping with a cloth dampened with water. If you see signs of deterioration or damage, replace the cable. Do not use it for further patient monitoring.

---

## Cleaning

This table lists the recommended cleaning agents for your fetal monitor and accessories.

	Mild soaps	Tensides	Alcohol-based	Aldehyde-based
Monitor	✓	✓	✓	✓
Brown Transducers	✓	✓	✓	✓
Blue Transducers	✓	✓	✓	✓
Belts	✓	✓	✓	✓
Patient Modules M1364A, M1365A	✓	✓	✓	✓
ECG Adapter Cables M1362A, M1363A	✓	✓	✓	✓
DECG Adapter Cable M1362B, ECG legplate adapter M1347A	✓	✓	✓	✓

---

**Caution**

**To avoid damage to the product, observe the following general precautions when cleaning unless instructed otherwise in the guidelines supplied with a specific product.**

---

Do not use strong solvents such as acetone or trichloroethylene. Always dilute according to the manufacturer's instructions, or use lowest possible concentration. Never use abrasive materials such as steel wool or silver polish. Never submerge any part of the system and do not allow liquid to enter inside the products. Wipe the cleaning agent off the surface of the equipment immediately with a damp cloth.

---

**Warning**

**Philips makes no claims regarding the efficacy of the listed chemicals or methods as a means for controlling infection. Consult your hospital's Infection Control Officer or Epidemiologist for information on infection control.**

**For comprehensive details on cleaning agents and their efficacy refer to "Guidelines for Prevention of Transmission of Human Immunodeficiency Virus and Hepatitis B Virus to health care and public safety workers" issued by the US Department of Health and Human Services, Public Health Service, Center for Disease Control, Atlanta, Georgia, February 1989.**

---

## Disinfecting

We recommend that you disinfect the fetal monitoring equipment only when necessary as determined by your hospital's policy, to avoid long term damage. Never immerse or soak any part of the monitoring system. Do not allow the disinfectant to remain on the equipment. Remove it immediately by wiping with a cloth dampened with water. Clean the equipment before disinfecting it.

This table lists the recommended disinfecting agents for your fetal monitor and accessories

Product	Alcohol-based	Aldehyde-based
Monitor	✓	✓
Brown Transducers	✓	✓
Blue Transducers	✓	✓
Patient Modules M1364A, M1365A	✓	✓
ECG Adapter Cables M1362A, M1363A	✓	✓
ECG legplate adapter cables M1362B, M1347A	✓	✓

Recommended disinfecting agent brands are:

Aldehyde-based	Buraton liquid <sup>®</sup> , dilution of formaldehyde (3-6%), Cidex <sup>®</sup> , Gigasept <sup>®</sup> , Kohrsolin <sup>®</sup>
Alcohol-based <sup>1</sup>	Ethanol 70%, Isopropanol 70%, Cutasept <sup>®</sup> , Hospisept <sup>®</sup> , Kodan <sup>®</sup> -Tincture forte, Sagrosept <sup>®</sup> , Spitacid <sup>®</sup> , Sterilium fluid <sup>®</sup>

1. Only Ethanol 70% and Isopropanol 70% are tested and qualified

---

**Caution**

**To avoid damage to the product, observe the following general precautions when disinfecting unless instructed otherwise in the guidelines supplied with a specific product.**

---

Do NOT use Povodine<sup>®</sup>, Sagrotan<sup>®</sup>, Mucovit<sup>®</sup> or strong solvents.  
Do NOT use strong oxidants such as bleach.  
Do NOT use bleaches containing sodium hypochlorite.  
Do NOT use disinfectants containing iodine complexes.  
If you intend to use a cleaning agent not listed here, check its material compatibility first.  
ALWAYS dilute according to the manufacturer's instructions.

Recommended Disinfecting Substances

Aldehyde-based	Cidex <sup>®</sup>
Alcohol-based	Ethanol 70%, Isopropanol 70%

---

**Sterilizing**

**Monitor, Patient Modules, Transducers**

It is not possible to sterilize the monitor, patient modules or transducers by means of autoclaving, gas treatment, formaldehyde process, or radiation.

**Adapter cables M1347A, M1362B**

It is not possible to sterilize adapter cables M1347A, M1362B by any means.

**Adapter cables M1362A, M1363A**

Only ECG adapter cables M1362A and M1363A can be sterilized. They can be sterilized by means of autoclaving or by gas sterilization. We recommend that you sterilize only when necessary as determined by your hospital's policy, to avoid long-term damage to the cable. We also

recommend that you clean the cables before sterilizing them. The M1362A and M1363A cables have been tested to withstand Ethylene Oxide (Et) gas sterilization. Be sure that all safety precautions regarding aeration after EtO exposure are followed. The cables are tested to withstand autoclaving at 136°C (277°F) maximum.

---

**Caution**

**Do not use bleaches containing sodium hypochlorite (for example Clorox™) on any of the cables.**

---

## IUP (1290C/CPJ840J5)

Refer to the instructions that accompany the transducer.

## IUP Transducer Adapter Cable

To remove blood and debris from the adapter cable 1271A Option J05, use Hemesol or an equivalent solvent. Do not:

- Immerse the electrical connectors in liquid. Doing so can damage the connector wiring.
- Steam-autoclave the interface cable. Moisture can damage the connector wiring.
- Use “cold sterilizing” solutions due to possibility of fluid contamination in electrical connectors. Sterilize through an ethylene oxide cycle using standard hospital procedure. When you are not using the interface cable, protect against connector damage by covering with the connector cap provided.

---

## Belts

Wash soiled belts with soap and water. Water temperature must not exceed 60°C (140°F).

---

## Reusable SpO<sub>2</sub> Transducers

Refer to the instructions that accompany the transducer.

---

## Non-invasive Blood Pressure Cuff

Refer to instructions that accompany the cuff.

---

## Storing Recorder Paper

Recorder paper is not intended for long-term archival storage. Another medium should be considered if this is required.

Dyes contained in thermal papers tend to react with solvents and other chemical compounds that are being used in adhesives. If these compounds come into contact with the thermal print, the print may be destroyed over time. You can take the following precautionary measures to help avoid this effect.

- Store the paper in a cool, dry and dark place.
- Do not store the paper at temperatures over 40°C (104°F).
- Do not store the paper where the relative humidity exceeds 60%.
- Avoid intensive light (UV light), as this may cause the paper to turn gray or the thermal print to fade.
- Avoid storing the thermal paper in combination with the following conditions:



- Papers that contain organic solvents. This includes papers with tributyl and/or dibutyl phosphates, for example recycled paper.
- Carbon paper and carbonless copy paper.
- Products containing polyvinyl chlorides or other vinyl chlorides for example (but not exclusively) document holders, envelopes, letter files, divider sheets.
- Detergents and solvents, such as alcohol, ketone, ester and others, including cleaning and disinfecting agents.
- Products containing solvent-based adhesives such as (but not exclusively) laminating film, transparent film or labels sensitive to pressure.

To ensure long lasting legibility and durability of thermal printouts, store your documents separately in an air-conditioned place and use



- only plasticizer-free envelopes or divider sheets for protection.
- laminating films and systems with water-based adhesives.

Using such protective envelopes cannot prevent the fading effect caused by other, external agents.

---

## Self Test

The monitor automatically performs a self test when you switch it on. There are two possible types of error that you might see. A fatal error prevents the monitor from functioning. A non-fatal error allows you to continue to work but warns you of a problem that must be resolved swiftly.

- If a non-fatal error occurs (for example, if the batteries are low):
  - An error message is displayed for ten seconds.
  - Err xxx , time and date are printed on the paper after ten seconds, and then every ten minutes.  
(“xxx” is the number of the error message.)
  - Switch the monitor off and then on. If the error occurs again, try to solve the problem or, if you cannot, contact your Philips Service Engineer or Medical Response Center.  
  
(If the recorder is not on when the monitor is switched on, Err xxx  time and date are printed when it is switched on subsequently.)
- If a fatal error occurs (for example, if a board is defective):
  - An error message is displayed for ten seconds
  - After ten seconds, the monitor tries to restart.If the error occurs again contact your Philips Service Engineer or Response Center.

## Quick Test

The quick test takes approximately 15 seconds and tests the basic electronics of the monitor. To carry out the test:

1. Remove any monitoring equipment plugged into the input sockets. Switch off or disconnect the telemetry receiver and any external devices connected to the monitor.
2. Switch on the monitor.
3. Press and release the test key. Check that:
  - The fetal displays flash, and the two halves of the maternal display flash alternately.
  - The recorder on/off light blinks in time with the display.
  - A test pattern is printed on the paper.

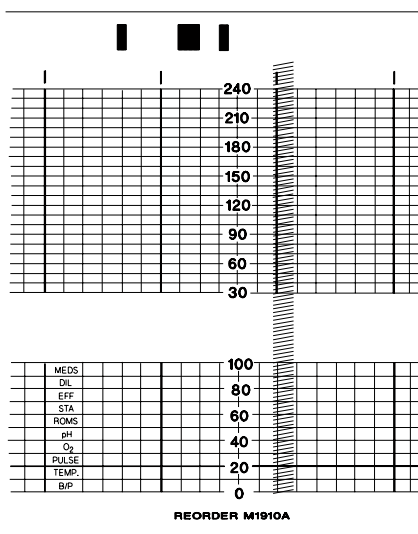

- Check the lines in this test pattern to ensure the heating elements on the printer head are operational. Lines printed on the colored grid lines may appear light, but this is not considered to be a fault.
- The monitor performs its power on test.

If any of these fail, contact your Philips Service Engineer or Response Center.

If an error occurs:

- An error message is displayed for ten seconds.
- Err xxx  time and date are printed on the trace after ten seconds, and then every ten minutes.
- (“xxx” is the number of the error message.)

To stop the error annotation printing, switch the monitor off and then on. If the error is repeated, contact your Philips Service Engineer or Response Center.

## Parameter Test

The parameter test checks the signal path to and from the input sockets, but not the transducers or patient modules themselves. To carry out the test:

1. Switch on the monitor and the recorder.
2. Connect the appropriate transducer to each socket.
3. Press and hold the test key.

The correct monitor response for each signal is:

Signal	Correct Monitor Response
US (Cardio 1) using M1356A	<b>190</b> is displayed and printed. Signal quality indicator is green. Fetal heartbeat is heard from loudspeaker.
US (Cardio 2) using M1356A	<b>170</b> is displayed and printed. Signal quality indicator is green. Fetal heartbeat is heard from loudspeaker.
Toco using M1355A	A signal alternating between <b>10</b> and <b>60</b> is displayed and printed.

Signal	Correct Monitor Response
DECG using M1364A, M1365A or M1357A	<b>200</b> is displayed and printed. Signal quality indicator is green. Fetal heartbeat is heard from loudspeaker.
MECG using M1364A, M1365A or M1359A	<b>120</b> is printed. <b>MECG</b> is on.
US/MECG (Cardio 1) using M1358A	<b>190</b> is displayed. <b>190</b> and <b>120</b> are printed. Signal quality indicator is green. MECG is on. Fetal and maternal heartbeats are heard from the loudspeaker.
SpO <sub>2</sub> using M1191A with M1940A	<b>99%</b> is displayed on LCD and printed. Pulse <b>120</b>  displayed on LCD.
FSpO <sub>2</sub> using M1365A	<b>88%</b> displayed.

If your monitor's response is different, contact your Philips Service Engineer or Response Center.

If an error occurs:

- An error message is displayed for ten seconds.
- Err xxx  time and date are printed on the paper after ten seconds, and then every ten minutes.  
(“xxx” is the number of the error message.)

To stop the error annotation printing, switch the monitor off and then on.

---

## Testing Transducers

If any of the following tests fail, repeat the test using another transducer. If it still fails, contact your Philips Service Engineer or Response Center.

### Toco

To test a Toco transducer:

1. Switch on the monitor and the recorder.
2. Connect the transducer to the Toco socket.
3. Gently apply pressure to the pick-up button.

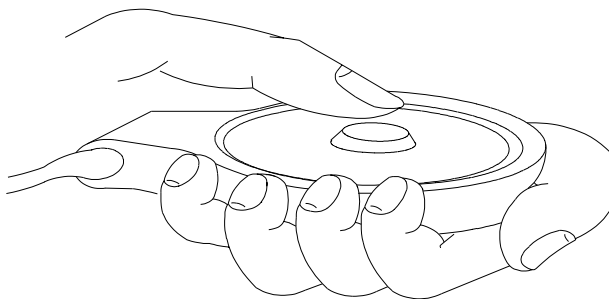

4. Check that the value on the display and paper shows this change in pressure.

### Ultrasound

To test an ultrasound transducer:

1. Switch on the monitor and the recorder.
2. Connect the transducer to the Toco socket.
3. Increase the loudspeaker volume to an audible level.

4. Holding the transducer in one hand, move your other hand repeatedly towards and then away from the surface.

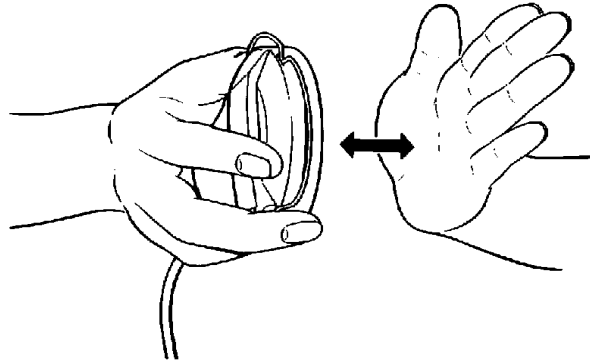

5. Check that a noise is heard from the loudspeaker.

## IUP

1. Switch on the monitor and the recorder.
2. Connect the transducer to the Cardio 1/Combi socket.
3. Gently apply pressure to the syringe plunger.  
Check that the value on the display and paper shows this change in pressure.



## ECG

1. Connect the ECG transducer to the fetal monitor, (M1364A, M1365A, M1357A, M1358A, M1359A).
2. Disconnect any electrodes and adapter cables from the transducer input.
3. Switch on the fetal monitor.
4. After the internal selftest has run, the display should show "NOP".  
If it does not, the transducer is defective and needs replacing.

---

## Replacing the Batteries

The monitor's internal clock is powered by two batteries that are located behind a panel at the rear. The average life span of these batteries is one year. We recommend replacing them during the annual preventative maintenance cycle. When the battery charge is low, the message

 is displayed, and  is printed on the recorder trace. When this happens, replace the batteries as soon as possible.

To replace the batteries:

1. Switch off the monitor and disconnect it from the mains supply.
2. Replace the batteries with two alkaline 1.5 Volt size N batteries.
3. Replace the mains supply and switch the monitor on.
4. Reset the time and date to prevent the wrong time and date from being printed on the recorder trace.

If the batteries are not replaced when necessary, the specific settings will return to their default values and will have to be reset each time the monitor is switched on. For example, the date is set to 4.4.44 and Toco baseline to 20 units. Leaking batteries could damage the monitor. If the monitor is not used for long periods, remove the batteries.



---

## Replacing the Fuses

Fuse values are printed on the rear of the monitor:

For 100/120V  $\sim$  Line Voltage T1A/250V

For 220/240V  $\sim$  Line Voltage T500mA/250V

( $\sim$  means “alternating current”)

To replace the fuses:

1. Switch off the monitor and disconnect it from the main power supply.
2. Using a flat-blade screwdriver, prise open the fuse cover.

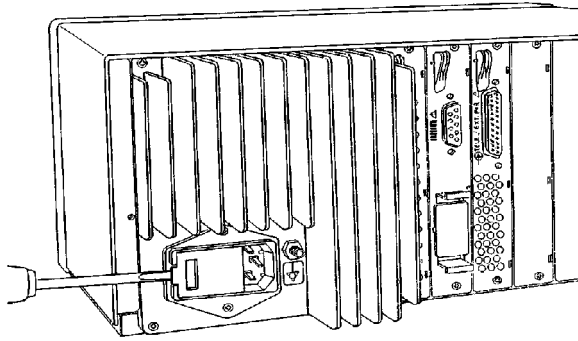

3. Lift the fuse holder slightly and pull it out.

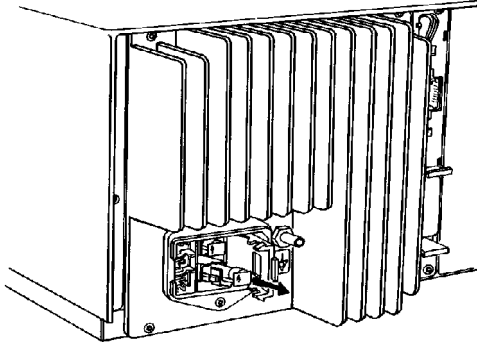

4. Remove the fuse from the holder and replace it with another of the correct value.
5. Slide the holder back into place, aligning the arrow on the holder with the arrow on the cover.
6. Repeat steps 3 to 5 for the second fuse.
7. Close the fuse cover.

# 19 Troubleshooting

---





## Introduction

Common problems that may occur during monitoring are dealt with in the relevant chapters in this book.

More details are given in the *Installation and Service Guide* for your monitor.

## Error Messages

Error	Display	Cause	Solution
Err 1	Cardio 1	Wrong transducer in Cardio 1/ Combi socket.	Connect correct transducer.
Err 1	Cardio 2	Wrong transducer in Cardio 2 socket.	Connect correct transducer.
Err 2	Toco	Wrong transducer in Toco socket.	Connect correct transducer.
Err 4	Cardio 2	US/MECG Combi transducer not allowed in this socket.	Only 1 x MECG or 1 x DECG are permitted in combination. Remove transducer.
Err 6	Cardio 1 Cardio 2	Wrong pairing of US/MECG Combi transducer, MECG transducer and DECG transducer.	Remove one of the transducers.
Err 8	Cardio 1 Cardio 2	Dual Ultrasound Twins option is not fitted.	Remove one of the transducers.
Err 9	Cardio 1 Cardio 2	Invalid telemetry mode.	Check the cable from the telemetry receiver and if, necessary, replace it.
Err 16	Cardio 1 Toco Cardio 2	Wrong pairing of telemetry and transducers.	Either disconnect the transducers or switch off the telemetry receiver.
Err 101	Cardio 1	FSpO <sub>2</sub> patient module defective.	Replace patient module M1365A.
Err 102	Cardio 1	Communication error - no connection between FSpO <sub>2</sub> patient module and monitor.	Replace patient module M1365A.
Err 103	Cardio 1	FSpO <sub>2</sub> sensor defective.	Use a new sensor.
<b>nop</b>	Cardio 1 Cardio 2	No contact, or poor contact, between reference electrode and mother.	Use a new spiral electrode.

Message	Cause	Solution
Err bAt <sup>1</sup>  <sup>2</sup>	Battery low or empty of charge	Change the batteries as soon as possible. If you do not change the batteries, your specific settings will return to their default values when the monitor is switched on. (For example, the date is set to 4.4.44.)
Err PAP 30-240  <sup>3</sup> Err 602 <sup>4</sup>	Incorrect type of paper loaded	Load paper with 50-210 scale or change the monitor's paper format setting (see the <i>Installation and Service Guide</i> ).
Err PAP 50-210  <sup>3</sup>	Incorrect type of paper loaded	Load paper with 30-240 scale or change the monitor's paper format setting (see the <i>Installation and Service Guide</i> ).
Err xxx  <sup>3</sup>	xxx is between 500 and 600. This indicates a technical failure diagnosed by the monitor's self test program.	Contact your Philips Service Engineer or Medical Response Center.
Error 601  <sup>3</sup>	Paper speed	<p>Check that correct paper is used. Check the speed by timing how long it takes for the paper to advance 1cm:</p> <p>60 seconds = 1cm/min 30 seconds = 2cm/min 20 seconds = 3cm/min</p> <p>Contact your Philips Service Engineer or Medical Response Center if the speed is incorrect.</p>

1. Displayed for ten seconds when the monitor is first switched on.
2. Printed every 10 minutes.
3. Printed every three pages.
4. Displayed for 10 seconds.

## Error Messages

---

## Introduction

This chapter lists the accessories supplied as standard and as options. Items are subject to availability and this chapter is not, therefore, a definitive listing. Do not use accessories that are not approved by Philips. You may damage the equipment and this type of damage is not covered by warranty.

---

## Standard Accessories

The following accessories are supplied as standard with the monitor:

### Fetal Accessories

- 1 x M1365A combined patient module for FSpO<sub>2</sub> and DECG or MECG plus adapter cables (Series 50 XMO only)
- 2 x M1356A ultrasound transducers
- 1 x M1355A Toco ext. transducer
- 4 x reusable transducer belts
- 3 x transducer knob adapters
- 1 x bottle of gel
- 5 x fetal scalp electrodes
- 1 x M1364A DECG patient module and adapter cables
- 1 x remote event marker.

## Maternal Accessories

- 1 x M1364A combined DECG/MECG patient module and adapter cable
- 1 x M1574A adult NIBP cuff
- 1 x M1575A large adult NIBP cuff
- 1 x M1599B NIBP monitor to cuff interconnect tubing (3.0m)
- 1 x M1191A reusable adult finger SpO<sub>2</sub> transducer
- 1 x M1940A adapter cable for Philips SpO<sub>2</sub> transducers.

## Documentation

- Quick Reference Guide
- Pocket Guide to Fetal Monitoring (English language shipments only)
- Operating Guide
- Installation and Service Guide
- Application Note: Fetal Oxygen Monitoring. Technical Issues (Series 50 XMO only)
- Sensor Placement Guide (Series 50 XMO only).

---

## Optional Accessories

The following accessories can also be supplied when the appropriate option is ordered.

Code	Option
C07	Pressure Transducer and IUP kit.
C08	M1333A disposable intrauterine sensor-tip pressure catheters and M1334A reusable connector cable.
H04	Paper tray.



Code	Option
H15	Barcode Reader, including a reader and barcode booklet.
J12	Combined analog/digital system interface for OBMS/ODIS.
J13	<p>Maternal parameter interface to connect external patient monitor. Use this only if your monitor has no internal maternal parameters installed. The following external devices can be connected:</p> <ul style="list-style-type: none"> <li>- M1165A/1166A/1175A/1176A Philips CMS.</li> <li>- 78352C/78354C Compact Configurable Monitors.</li> <li>- Dinamap 1846 and 8100 NIBP Monitors. A model 8801 adapter is required from General Electric to connect the Dinamap 8100.</li> <li>- Press-Mate/Listmini Model-BP-8800 NIBP Monitor.</li> <li>- Accutorr 3, Accutorr 3 (Sat)</li> <li>- Accutorr 4, Accutorr 4 (Sat) NIBP (SpO<sub>2</sub>) Monitors.</li> <li>- Nellcor N-200 Maternal SpO<sub>2</sub> Monitor</li> <li>- Nellcor OxiFirst™ Fetal Oxygen Saturation Monitor (N-400). One interface cable is provided with this option. If you want to connect a Nellcor monitor in addition to one of the other monitors, order a second interface cable M1350-61609. This is for Series 50 XM only.</li> </ul>
2AE	Cart CL.
2AF	Cart CM.
2AG	Cart CX.
0B5	Video Operating Guide.

---

## Paper

Use only the following types of paper:

Product Number	Country	FHR Scale	Color of Grid	kPa Scale	Highlighted 3cm Lines
M1910A	USA/Canada	30-240	Orange	No	Yes
M1911A	Europe/Japan	50-210	Green	Yes	No
M1913A	Japan	50-120	Green	No	Yes
M1913J	Japan	50-210	Green <sup>1</sup>	No	Yes

1. Normal bradycardia and tachycardia ranges alarm ranges are yellow; severe bradycardia and tachycardia ranges are red.

The paper is chemical/thermal, fanfold, with a labor scale of 0 to 100 units @ 25 units/cm. Each pack of paper has 150 numbered pages. Paper is supplied in cases of 40 packs.

Do not use paper with sprocket holes intended for 8040A/8041A Fetal Monitors as the trace may not be legible and a paper jam may occur.

---

## Gels

**40483A** Aquasonic transmission gel for use with ultrasound transducers.

- Available worldwide.
- Water-soluble.
- Easy patient clean-up.
- Supplied in packs of 12 bottles (each 250ml).
- 

**40483B** 5-liter refill container (with dispenser) to refill 40483A bottles. Shelf life: 24 months maximum; 6 months minimum.

---

## Transducers and Patient Modules

All transducers are supplied individually.

**M1355A** Toco Transducer

**M1356A** Ultrasound Transducer

**M1358A** US/MECG Combi transducer for ultrasound or MECG monitoring

**M1359A** MECG Transducer

**M1365A** FSpO<sub>2</sub>/ECG combined patient module

**M1364A** ECG only patient module

---

## MECG Electrodes and Cables

**M1363A** Reusable MECG adapter cable for M1364A or M1365A patient module.

**40493D** Disposable pre-gelled electrode for abdominal ECG.

- Silver/silver-chloride sensor
- Pre-gelled
- 54mm (2in) diameter
- Foam-backed
- Supplied in packs of 5
- (1 case = 4 boxes = 60 packs = 300 electrodes)
- Shelf life: 18 months maximum; 6 months minimum.

**M1531B** Electrode cable for MECG electrode 40493D.

- Supplied in packs of 4.

---

## DECG Cables

- M1362A** Reusable DECG adapter cable for M1364A or M1365A patient module, for open-wire electrodes.
- M1362B** Reusable DECG adapter cable for M1364A or M1365A patient module, scalp electrodes with a connector.
- M1349A** Pad electrode for fixing M1362B

---

## Disposable Scalp Electrodes

- 15133D** Available in Europe only.
- Double spiral
  - Driven by inner drive tube
  - Gamma sterilized
  - Supplied in packs of 25. Shelf life: 24 months maximum; 6 months minimum.
- 15133E** Available worldwide.
- Single spiral
  - Driven by inner drive tube
  - Radiation sterilized
  - Supplied in packs of 50
  - Shelf life: 24 months maximum; 6 months minimum.

---

## Fetal Oxygen Sensor

**Nellcor FS14**

Must be ordered directly from the local Tyco Healthcare distributor.

---

## IUP Transducers

**CPJ840J5**

IUP pressure transducer, supplied with transducer holder CPJ84046. Use with sterile disposable domes CPJ84022.

---

## IUP Catheters

**M1333A**

Disposable intrauterine sensor-tip pressure catheter (5 mV/VmmHg  $\pm$  2% tolerance). Supplied in boxes of 10. M1353A Option C08 includes one box of catheters (M1333A) and one reusable connector cable M1334A. Worldwide availability.

- Radiation sterilized
- Contains 10 disposable catheters
- Shelf life 24 months maximum: 6 months minimum

Related products: M1334A reusable connector cable for use with M1333A catheter.

---

## Domes

### **CPJ84022**

Sterile, disposable dome for use with IUP pressure transducer CPJ840J5.

- Supplied in packs of 50.
- Shelf life: 18 months maximum.

---

## IUP Transducer Holder

### **CPJ84046**

IUP Transducer holder

- For use with IUP pressure transducer CPJ840J5.
- Supplied in packs of four.

---

## Maternal Accessories

### **NIBP Accessories**

#### **Non-Sterile Cuffs**

- M1876A (small adult)
- M1877A (adult)
- M1878A (large adult)
- M1879A (thigh)

#### **Sterile Cuffs**

- M1808A (small adult)
- M1809A (adult)
- M1829A (large adult)

**Reusable Cuffs**

- M1573A (small adult)
- M1574A (adult)
- M1575A (large adult)
- M1576A (thigh)

**Long Life Cuff Kit**

- M1578A (contains M1573A, M1574A, M1575A and M1576A)

**Interconnect Tubings**

- M1598A (1.5m)

**SpO<sub>2</sub> Accessories****Philips Transducers**

- M1191A (requires M1940A adapter cable)
- M1192A SpO<sub>2</sub> Small Adult (requires M1940A adapter cable)
- M1194A SpO<sub>2</sub> clip (ear) (requires M1940A adapter cable)

**Philips/NELLCOR Disposable Transducers**

Each of the following transducers requires adapter cable M1900B which must be ordered separately.

- M1904B (Oxysensor II D-25 adult)
- M1903B (Oxysensor II D-20 small adult)

**Adapter Cables**

- M1900B connector cable for Philips/NELLCOR transducers
- M1940A adapter cable for Philips transducers

## **Belts and Buttons**

### **Reusable Abdominal Transducer Belt (M1562A)**

- Pre-cut.
- Width: 50mm
- Length: 1.3m
- Supplied in packs of 5.

### **Belt Buttons (M1569A)**

- Supplied in packs of ten.

### **Transducer Knob Adapter (M1356-43201)**

- Supplied in packs of three.



# 21 Specifications

---

## Introduction

The following section gives the manufacturer's specification for the monitor.

---

## Patient Safety

The monitor is designed to comply with:

- IEC 60601-1/EN 60601-1
- UL 2601-1
- CSA-C22.2 No 601.1-M90

Parameter	Input Connector	Resulting Isolation
IUP, TOCO, NIBP, SpO <sub>2</sub>	CF	CF
US (M1356A)	B	B
DECG (M1357A)	B	CF
MECG (M1359A)	B	CF
DECG <b>or</b> MECG via M1364A	B	CF
FSpO <sub>2</sub> and <b>either</b> MECG <b>or</b> DECG via M1365A	B	CF

None of the ECG modes are electrosurgery proof.

---

## Operating and Environmental

<b>Power Requirements</b>	Operating Voltage	100 - 120 V ( $\pm 10\%$ ) 220 - 240 V ( $\pm 10\%$ )
	Line Frequency	50 to 60 Hz
	Power Consumption	60 VA max
<b>Environment</b>	Operating Temperature	0°C to + 55°C
	Storage Temperature <sup>1</sup>	-40°C to +75°C
	Relative Humidity	5% to 95%°
<b>Dimensions and Weight without transducers</b>	Height	147 mm (5.8in)
	Width	422mm (16.6in)
	Depth	392mm (15.4in)
	Weight	14.6kg (31.96lb)

1. Excludes transducers. Transducers can be stored at temperatures from -40°C to +60°C.

---

## Fetal Display

<b>Heart Rate Range</b>	US	50 to 240 bpm
	DECG	30 to 240 bpm
	MHR	30 to 240 bpm (not displayed)
<b>External Toco Range</b>		0 to +127 relative units
<b>IUP Range</b>		-99 to +127 mmHg
<b>Fetal SpO<sub>2</sub> Range</b>	0 - 99%	

---

## Maternal Non-invasive Blood Pressure

<b>Pressure Transducer Accuracy</b>	15°C to 25°C	±3 mmHg
	10°C to 35°C	±3 mmHg (±0.6% of reading)
	0°C to 55°C	±3 mmHg (±1.7% of reading)
<b>Measurement Ranges</b>	Systolic	30 to 270 mmHg
	Diastolic	10 to 245 mmHg
<b>Cuff Inflation Rate</b>	Typically less than 10 seconds	
<b>Auto Mode Repetition Time</b>	2, 5, 10, 15, 30, 60 minutes	
<b>Stat Mode Duration</b>	5 minutes	

Maternal Non-invasive Blood Pressure

<b>Cycle Time (Typical at HR over 60 bpm)</b>	Auto/manual	35 seconds
	Stat	17 seconds
	Maximum	120 seconds
<b>Limit Alarms</b>	Adjustment	5mmHg steps
	Diastolic	10 to 245mmHg
	Systolic	30 to 270mmHg
	Overpressure Safety Limit	300 mmHg for more than 2 seconds
<b>Pulse Rate Range</b>	Measurable within heart rate range of 30 to 240 bpm, averaged during NIBP measurement.	

---

## Maternal Pulse Oximetry

<b>Percentage Range</b>	0 to 100%		
<b>BPM Range</b>	30 to 300 bpm		
<b>Accuracy</b>	± 1%		
<b>Resolution</b>	1 bpm		
<b>Pulse Rate Limit Alarms</b>	Range	70% - 90%	
	Adjustment	1% steps	
<b>Accuracy at 1 standard deviation</b>	M1191A	70 to 100%	± 2.5%
	M1192A	70 to 100%	± 2.5%
	M1194A	70 to 100%	± 4%
	Nellcor sensors	80 to 100%	± 3%

---

## Maternal ECG and Heart Rate

<b>Heart rate Measurement</b>	Range	30 to 240 bpm
	Accuracy	±1 bpm
	Resolution	Recorder: 0.25 bpm Display: 1 bpm
<b>Heart rate Alarm Limits (excluding NIBP)</b>	Range	30 to 250 bpm
	Adjustment	5 bpm steps

---

## Maternal Display Section

### Numerical Display

Two heart rate displays (orange) and one uterine activity display (green).  
Type: (10mm) 7 segment LEDs.

### Maternal Display

The maternal display shows:

- systolic measurement
- diastolic measurement
- SpO<sub>2</sub> level
- maternal heart rate (if derived from MECCG), pulse rate (if derived from pulse oximetry) or average pulse rate (if derived from NIBP)
- Alarm status for each parameter (except NIBP pulse rate)
- Warning message (if any)

---

## Mode Display

Mode display for MECCG and Telemetry (Telemetry mode will be displayed when an M1310A Fetal Telemetry System is connected and powered up.)

Two signal quality indicators (cardio channels only): green, yellow and red show signal quality. Acceptance lamps flash with valid heart rate measurement (M1350B only).

## Ultrasound, External and Internal Toco

<b>Ultrasound Mode</b>	System	Pulsed Doppler oscillator
	Frequency	998.4kHz
	Repetition Rate	3.2kHz
	Ultrasound Intensity	1.5mW/cm <sup>2</sup> average for each of the seven active surfaces (using M1356A transducer)
<b>External Labor</b>	Signal Range	0 to 100 units
	Offset Compensation	±200 units
<b>Intrauterine Pressure</b>	Signal Range	-99 to +127mmHg
	Patient Leakage Current	10µA. Displayed pressure unit mmHg.
	Sensitivity	Automatically selectable between 40µV/V/mmHg (M1348A) and 5µV/V/mmHg (M1334A and CPJ840J5)

## Recorder

Recorder mechanism: 5 channel, high resolution (8 dots per mm, 200 dots per inch) thermal array recorder, paper end detection. Paper speeds 1, 2 and 3cm/min.

Annotation: time of day and date (automatic annotation every 10 minutes), paper sensing mode (annotated with each alteration of parameter).

Paper advance speed: 24cm/min. Automatic stop at perforation line.

## FHR (Cardio) Scales

	Scale A	Scale B	Uterine Activity (Toco) Scale
<b>Vertical Scale Size</b>	7cm	8cm	4 cm
<b>Vertical Scale Sensitivity</b>	30 bpm/cm	20 bpm/cm	25 units/cm
<b>Range</b>	30 to 240 bpm	50 to 210 bpm	0 to 100 units

Z-fold paper with numbered pages

Recording times per pack:

8h 20min at 3cm/min.

12h 30min at 2cm/min.

25h at 1cm/min.

Fetal Movement Profile (FMP) recording:

2 mm high bars on upper Toco scale.

## Testing Facilities

Test button: With no front end connections to the instrument a thorough instrument test is performed including a display and recorder test. With the appropriate transducer connected the respective mode can be tested. See Chapter 18, "Maintenance and Performance Assurance".



---

**Declaration**

These medical devices comply with the requirements of the Medical Devices Directive (93/42/EEC) concerning medical devices.

This product is classified as Class IIb in accordance with Annex IX of the Medical Devices Directive (93/42/EEC).

Manufactured by: Philips Medizinsysteme Boeblingen GmbH  
Hewlett-Packard Str. 2, Boeblingen,  
Germany

Product Name: Fetal Monitor Series 50 XM and 50 XMO

Model Numbers: M1350B and M1350C

Standards complied with:

Safety, Performance EN60601-1:1990+A1:1993+A2:1995  
{IEC 60601-1:1988+A1:1991+A2:1995}

EMC EN60601-1-2:1993  
{IEC 60601-1-2:1993}

Declaration

---

## Manufacturer's Responsibility

Philips only considers itself responsible for any effects on safety, reliability and performance of the equipment if:

- Assembly operations, extensions, re-adjustments, modifications or repairs are carried out by persons authorized by Philips, and
- The electrical installation of the relevant room complies with national standards, and
- The instrument is used in accordance with the instructions for use.

---

## Warranty

Philips hardware products are warranted against defects in materials and workmanship. If Philips receives notice of such defects during the warranty period, Philips shall, at its option, either repair or replace hardware products which prove to be defective. Some newly manufactured products may contain selected remanufactured parts equivalent to new in performance.

Philips software and firmware products which are designated by Philips for use with a hardware product, when properly installed on that hardware product, are warranted not to fail to execute their programming instructions due to defects in materials and workmanship. If Philips receives notice of such defects during the warranty period, Philips shall repair or replace software media and firmware which do not execute their programming instructions due to such defects. Philips does not warrant that the operation of the software, firmware or hardware shall be uninterrupted or error free.

If Philips is unable, within a reasonable time, to repair or replace any product to a condition as warranted, Customer shall be entitled to a refund of the purchase price upon return of the product to Philips.

#### 1. Duration and Commencement of Warranty Period

The warranty period for each product is one year, depending upon the warranty classification code of the product at time of order. The applicable warranty code shall be specified on the Philips Price List. The warranty period begins either on the date of delivery or, where the purchase price includes installation by Philips, on the date of installation. If Customer schedules or delays installation more than thirty (30) days after delivery, the warranty period begins on the thirty-first (31st) day from the date of delivery.

#### 2. Place of Performance

Within Philips service travel areas, warranty and installation services for products installed by Philips and certain other products designated by Philips will be performed at Customer's facility at no charge. Outside Philips service travel areas, warranty and installation services will be performed at Customer's facility only upon Philips's prior agreement and Customer shall pay Philips's round trip travel expenses and applicable additional expenses for such services.

On-site warranty services are provided only at the initial installation point. If products eligible for on-site warranty and installation services are moved from the initial installation point, the warranty will remain in effect only if Customer purchases additional inspection or installation services at the new site.

For product warranties requiring return to Philips, products must be returned to a service facility designated by Philips. Portable products (battery powered) and products purchased under Philips' international prices can be returned to the closest authorized Philips repair depot worldwide. All other products with return to Philips warranty must be returned to one of the authorized repair depots within the country of original purchase. Customer shall prepay shipping charges (and shall prepay all duty and taxes) for products returned to Philips for warranty service. Except for products returned to Customer from another country, Philips shall pay for return of products to Customer.

Installation and on-site warranty services outside the country of initial purchase are included in Philips' product price only if Customer pays Philips international prices (defined as destination local currency price or

Export price). Service outside the country of initial purchase is subject to the conditions regarding Philips service travel areas and initial installation point described above.

### 3. Limitation of Warranty

The foregoing warranty shall not apply to defects resulting from:

- a. Improper or inadequate maintenance by Customer;
- b. Customer-supplied software or interfacing;
- c. Unauthorized modification or misuse;
- d. Operation outside of the environmental specifications for the product; or
- e. Improper site preparation and maintenance.

TO THE EXTENT ALLOWED BY LOCAL LAW, THE WARRANTY SET FORTH ABOVE IS EXCLUSIVE AND NO OTHER WARRANTY, WHETHER WRITTEN OR ORAL, IS EXPRESSED OR IMPLIED AND PHILIPS SPECIFICALLY DISCLAIMS THE IMPLIED WARRANTIES OF MERCHANTABILITY AND FITNESS FOR A PARTICULAR PURPOSE

### 4. Australia and New Zealand Only

For consumer transactions the warranty terms contained in this statement, except to the extent lawfully permitted, do not exclude, restrict or modify and are in addition to the mandatory statutory rights applicable to the sale of this product to you.



---

## M1350 XM, XMO Fetal Monitoring Lab Evaluation

### Competency Statement

The Student will be able to perform the basic monitoring functions.

### Performance Objectives

The following objectives provides evidence of minimum achievement of the above competency. The student will explain or demonstrate how to:

1. Identify the components of the fetal monitor.
2. Perform a quick test on the monitor.
3. Perform a transducer check.
4. Load and advance the recorder paper.
5. Identify and connect the ultrasound (US) transducers.
6. Adjust the fetal heart rate (FHR) volume.
7. Explain and adjust the FHR offset feature for twin FHR monitoring.
8. Identify and connect the Toco transducer.
9. Identify and connect the intrauterine pressure (IUP) catheter.
10. Identify the maternal vital sign measurements available and connect the appropriate cables for the measurements.
11. Identify the types of maternal alerts available and silence the alerts.
12. Describe the fetal movement profile (FMP) measurement and enable the measurement.
13. Change the clock time and replace the battery.

14. Turn off and on the arrhythmia logic feature.
15. Identify the symbol for cross channel verification that is printed on the recorder paper.
16. Mark an event on the fetal tracing.

## Maternal Parameters

17. Distinguish the pulse source for the maternal heart rate.
18. Obtain the maternal ECG waveform.
19. Perform a maternal SpO<sub>2</sub> measurement.
20. Identify the NBP setup screens and obtain a reading.
21. Adjust the screen contrast and the alarm volume on the fetal monitor.

## Fetal SpO<sub>2</sub>

22. Identify the elements of the FSpO<sub>2</sub> display.
23. Identify the causes of FSpO<sub>2</sub> alarms.

## Fetal Telemetry

24. Identify the components of the fetal telemetry system.
25. Identify causes of transmission INOP conditions.
26. Describe the interface of the telemetry receiver to the fetal monitor.
27. Identify the steps to successful connect the fetal telemetry system to a fetal monitor.

## Resources

If there are additional questions the following resources are available:

1. Instructions for Use
2. Quick Instructions for Use
3. Series 50 XM & 50 XMO Fetal Monitor Video Operating Guide
4. M1310A Setting Up and Using Your Fetal Telemetry System



### Fetal Monitor Lab Evaluation

1. Identify each of the following components and describe its function:

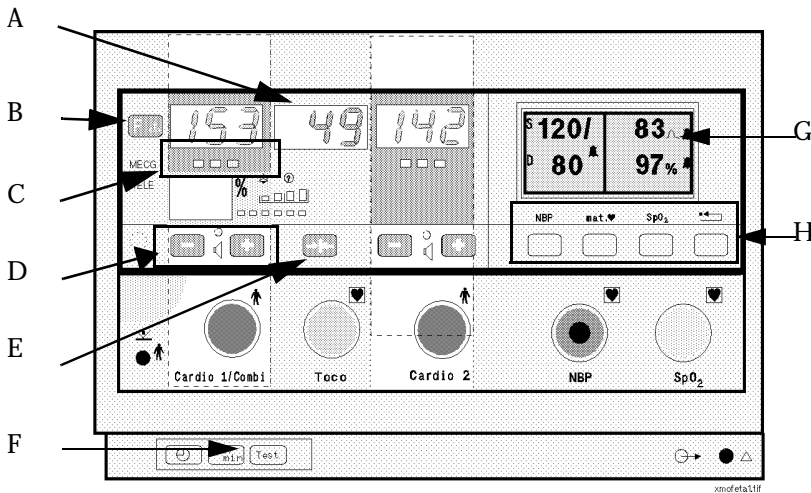

A. \_\_\_\_\_ Function: \_\_\_\_\_

B. \_\_\_\_\_ Function: \_\_\_\_\_

C. \_\_\_\_\_ Function: \_\_\_\_\_

D. \_\_\_\_\_ Function: \_\_\_\_\_

E. \_\_\_\_\_ Function: \_\_\_\_\_

F. \_\_\_\_\_ Function: \_\_\_\_\_

(Items G. and H. apply if monitors have Maternal parameters)

G. \_\_\_\_\_ Function: \_\_\_\_\_

H. \_\_\_\_\_ Function: \_\_\_\_\_

2. Identify each of the following items:

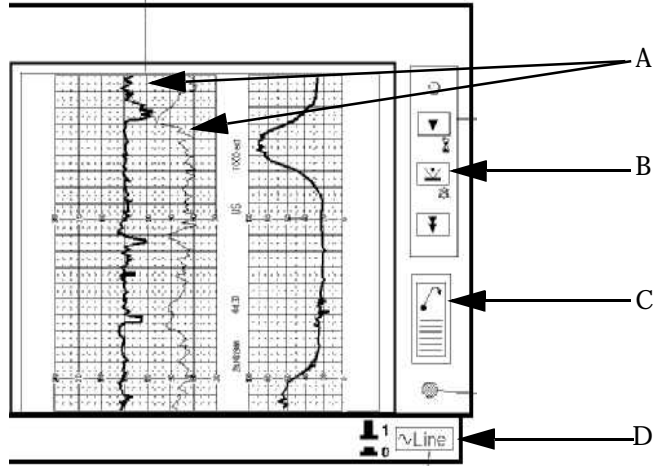

A. \_\_\_\_\_ B. \_\_\_\_\_  
 C. \_\_\_\_\_ D. \_\_\_\_\_

3. Load paper in the recorder.

4. a. Perform a Monitor Quick Test.  
 b. What displays in the Cardio 1/ Combi, Cardio 2 and Toco digital display windows? \_\_\_\_\_  
 c. Why should you review the test pattern on the recorder paper?  
 \_\_\_\_\_  
 d. What does the quick test check? \_\_\_\_\_

5. a. Perform a parameter test.  
 b. In the space below, write the values that are shown in the associated display window and recorded for each parameter during the parameter test.  
 US transducer in the Cardio 1/Combi socket \_\_\_\_\_  
 DECG transducer in the Cardio 1/Combi socket \_\_\_\_\_  
 Toco transducer in the toco socket \_\_\_\_\_  
 US and MECG cable in the Cardio 1/Combi socket \_\_\_\_\_  
 c. The parameter test checks the signal path to and from the input sockets but does not check the transducer or the module itself.  
 True or  False

6. a. How can you check the US and Toco transducers to ensure they are working properly? \_\_\_\_\_  
 \_\_\_\_\_  
 b. List two possible causes of transducer damage in the clinical setting  
 \_\_\_\_\_  
 \_\_\_\_\_
7. a. With the recorder on, mark an event.  
 b. What symbol displayed on the recorder paper when an event is marked?  
 \_\_\_\_\_  
 \_\_\_\_\_
8. List three items that will be visible on a trace recording:  
 a. \_\_\_\_\_ b. \_\_\_\_\_ c. \_\_\_\_\_
9. a. FMP is available only in the  Cardio 1/Combi or  Cardio 2 channel.  
 b. Turn off the FMP.  
 c. How is FMP depicted on a recording? \_\_\_\_\_  
 d. FMP detects \_\_\_\_\_
10. When you are receiving the best possible signal from the ultrasound transducer, the color of the signal quality indicator light will be \_\_\_\_\_
11. a. How do you know which baby's heart rate is being heard from the loud speaker? \_\_\_\_\_  
 b. Adjust the volume.
12. a. What is the purpose of Arrhythmia Logic? \_\_\_\_\_  
 \_\_\_\_\_  
 b. It applies to the signal from the  US or  DECG.  
 c. Turn the Arrhythmia Logic off.  
 d. Why might you turn Arrhythmia logic off? \_\_\_\_\_
13. a. When monitoring twins, the FHR offset is helpful because \_\_\_\_\_  
 \_\_\_\_\_  
 b. The +20 offset will display on the FHR trace for the  Cardio 1/Combi or  Cardio 2 channel.  
 c. The trace shows that the offset is active by \_\_\_\_\_  
 \_\_\_\_\_
14. a. When the system detects that ultrasound transducers are picking up the same heart rate (cross channel verification), what symbol is printed on the recording? \_\_\_\_\_

- b. What action should you take when cross channel verification has been detected? \_\_\_\_\_
  - c. You should periodically compare the mother's pulse with the signal coming from the fetal monitor's loudspeaker to ensure you are detecting the fetal heart rate.  True or  False.
15. a. Zero the external Toco transducer.
- b. What indication on the recorded trace shows that you are using an external Toco transducer? \_\_\_\_\_
16. a. Zero the internal uterine Pressure (IUP) catheter.
- b. What value will be displayed? \_\_\_\_\_
17. a. The key to adjust the clock time is located \_\_\_\_\_.
- b. The batteries maintain the clock time when the FM is off. The batteries are located \_\_\_\_\_
18. a. Set the Non Stress Test timer (NST) for 20 minutes.
- b. When the set time interval has passed, which of the following will happen. (select all that apply)
- A. Audible tone.
  - B. Recorder starts a new recording for another 20 minute interval.
  - C. Recorder stops and advances to next perforation (if configured).
  - D. Fetal monitor turns off.
- (question 19 applies to monitors purchased outside the USA)
19. a. Set the high fetal heart rate alarm to 160bpm.
- b. Which key will silence the alarm? \_\_\_\_\_

## Maternal Parameters

20. a. Describe how to apply the correct size NBP cuff for the patient.  
\_\_\_\_\_
- b. Set the NBP frequency to take a blood pressure every 15 minutes.
- c. An average maternal pulse can be obtained during the blood pressure measurement only when \_\_\_\_\_ and is indicated by a \_\_\_\_\_ symbol next to the pulse value.
- d. Which of the following are limitations or situations which could affect the accuracy of the NBP value: (select all that apply)
- A. Maternal heart rate below 30 or above 240 bpm.
  - B. Arterial pulse pressure which is changing rapidly during the blood pressure measurement.

- C. Hypothermia.
  - D. Uterine contraction during the blood pressure measurement time.
21. Adjust the alarms for the NBP to alert for a high systolic pressure of 180 mmHg or a low systolic pressure of 90 mmHg.
22. a. When you use the STAT mode for NBP, the monitor will \_\_\_\_\_  
 \_\_\_\_\_  
 b. The patient should always be supervised while using the STAT mode.   
 True or  False
23. a. If no MECG waveform is required, describe the electrode placement.  
 \_\_\_\_\_  
 b. If the MECG waveform is required, describe the electrode placement.  
 \_\_\_\_\_  
 c. Display and print the MECG trace.
24. a. Obtain an SpO<sub>2</sub> reading.  
 b. Describe the icon displayed by the maternal HR value when the pulse source is from the SpO<sub>2</sub> sensor? \_\_\_\_\_  
 c. The SpO<sub>2</sub> value is recorded on the trace every \_\_\_\_\_ minutes, or every \_\_\_\_\_ minutes if the alarm limit is exceeded.  
 d. List three situations that could affect accurate SpO<sub>2</sub> monitoring. \_\_\_\_\_  
 \_\_\_\_\_

## Fetal SpO<sub>2</sub>

25. Identify the following elements of the fetal SpO<sub>2</sub> display.

The diagram shows a fetal SpO<sub>2</sub> monitor display. On the left, a large digital display shows '70'. To its right is a percentage sign (%). Further right is a small icon of a fetal head with a pulse line. Below these are four vertical bars of increasing height, representing a trend. At the bottom are five small square icons. Labels A, B, C, and D point to these elements respectively.

A. \_\_\_\_\_  
 \_\_\_\_\_  
 B. \_\_\_\_\_  
 \_\_\_\_\_  
 C. \_\_\_\_\_  
 \_\_\_\_\_  
 D. \_\_\_\_\_  
 \_\_\_\_\_

26. The FSpO<sub>2</sub> alarms can be generated when: (select all that apply)
- A. FSpO<sub>2</sub> drops below the defined low limit.
  - B. FSpO<sub>2</sub> elevates above the defined high limit.

- C. FSpO<sub>2</sub> is below the low limit longer then the configured delay time.
- D. FSpO<sub>2</sub> is above the high limit longer then the configured delay time.

## Fetal Telemetry

27. The Fetal telemetry system is made up of a \_\_\_\_\_, a \_\_\_\_\_ and the patient cables.
28. List two possible reasons why the transmission INOP indicator light will be on. \_\_\_\_\_  
\_\_\_\_\_.
29. The Fetal telemetry receiver interfaces to the Fetal Monitor by \_\_\_\_\_  
\_\_\_\_\_.
30. Number each of the steps in the order in which you would perform them to monitor with the Fetal telemetry
  - \_\_\_ connect the transducer cables and turn on transmitter
  - \_\_\_ connect the interface cable between the receiver and the fetal monitor
  - \_\_\_ switch on the receiver
  - \_\_\_ remove transducer cables from the fetal monitor then turn it ON.
  - \_\_\_ insert the battery into the transmitter
  - \_\_\_ check that transmitter and receiver numbers match

## Answers

1. A. Toco or IUP Value - shows numeric uterine pressure measurement.  
B. Function key - allows access to other functions such as LOGIC and FMP.  
C. Signal Quality Indicator - indicates how good the signal is from the US transducer.  
D. Speaker key - allows adjustment of the audible volume for Cardio 1/Combi.  
E. Toco Baseline key - zeros the Toco display and trace to 20 units for external monitoring or to zero for internal pressure monitoring.  
F. Test key - used to perform monitor test before each use of monitor.  
G. Maternal parameter keys - allow access to setting alarms, making adjustments and performing measurements.  
H. Maternal pulse icon - indicates which source is used to obtain the pulse.
2. a. Cardio 1/Combi and Cardio 2 traces  
b. Event marker key  
c. Paper eject button

- d. On/off key
3. With the recorder off, push the paper eject button. With the drawer fully open, push and hold the eject button then lift out the remaining paper. Place the new paper in the tray with the bottom side down. Unfold the top page of the pack. The uterine activity scale will be to the right. Push the drawer back until it clicks. Press the Recorder On/Off key. Press and release the Paper Advance key to advance the paper to the next fold.
  4.
    - a. To perform the monitor quick test: remove all cables from the monitor input sockets then switch the monitor on. Press and release the Test key.
    - b. The Cardio 1/Combi, Cardio 2 and Toco display windows flash 888 alternately with the signal quality indicator light, MECCG and tele lights. The two halves of the maternal display, if present, will flash alternately a dark and light pattern. The recorder on/off light will blink and a test pattern will print.
    - c. Observe the test pattern lines for completeness to ensure the printer head is operational.
    - d. The basic electronics of the system is checked.
  5.
    - a. The parameter test is performed by connecting the appropriate transducer to a monitor which is on. Turn the recorder on. Press and hold the test key.
    - b. The following information is displayed and printed  
 US in the Cardio 1/Combi socket - 190 is displayed and printed  
 DECCG in the Cardio 1/Combi socket - 200 is displayed and printed  
 Toco in the toco socket - alternating value of 10 and 60 is displayed and printed  
 MECCG in the Cardio 1/Combi socket - 190 is displayed; 190 and 120 is printed.
    - c. True.
  6.
    - a. Plug in the US transducer and increase the loudspeaker volume. Move your hand closer to and away from the transducer or softly tap to simulate sound. The loudspeaker should beep for each simulated beat. Plug in the Toco transducer. Press on the Toco transducer and note the pattern on the trace and value on the screen.
    - b. The major way a transducer can be damaged is by improper handling such as by dropping, running over the transducers with bed or wrapping the cords too tightly.

7.
  - a. Press the event marker key or press the button on the remote event marker.
  - b. A small arrow prints on the FHR scale at the exact time the button or key was pressed. The width of the arrow depends on the duration the button is pressed.
8. Any three of the following: FHR trace, Toco trace, date and time, paper speed, notes, mode of monitoring, FMP, FMP statistics, FSpO<sub>2</sub> trace, maternal BP, maternal ECG, maternal HR, maternal SpO<sub>2</sub>, scale, marked event arrow, cross channel verification symbol.
9.
  - a. FMP can only be measured by a transducer in the Cardio 1/Combi socket.
  - b. Connect an US cable to the Cardio 1/ Combi socket. Press the Function key until FMP appears. Press the [--] or the [+ ] key to change the setting. The signal quality indicator is red when FMP is off. Press the Function key.
  - c. FMP is depicted above the Toco trace as blocks that vary in width based on the duration of the noted activity. The arrow in front of FMP indicates when the FMP statistics started. The statistics are printed every 10 minutes.
  - d. FMP detects gross fetal body movements via an ultrasound transducer.
10. When you are receiving the best possible signal from the ultrasound transducer, the color of the signal quality indicator light will be green.
11.
  - a. The cardio socket with the active speaker will have a light above the speaker icon to identify it as the audio source.
  - b. To adjust the volume press [--] to decrease or [+ ] to increase.
12.
  - a. The purpose of arrhythmia logic is to avoid recording artifact. When on, it does not record instantaneous heart rate changes of greater than 28 bpm and resumes when successive beats fall in predetermined limits. The FHR numeric displays the detected value and the audio speaker beeps appropriately for each beat detected.
  - b. It applies to the signal from the DECG.
  - c. To turn the Arrhythmia Logic off, with the DECG cable plugged in, press the Function key repeatedly until the monitor displays LOG. Use [-- ] or [+ ] to turn the logic off. Red indicates logic is off.
  - d. When you suspect fetal arrhythmias.



13.
  - a. When monitoring twins, the FHR offset is helpful because you can separate the similar baselines for easier interpretation of the recorded trace. The FHR value displayed on the fetal monitor is the correct value.
  - b. The trace will display the Cardio 1/Combi with a +20 offset.
  - c. The trace depicts that the offset is active by a vertical dotted line on the Cardio 1/Combi trace with the symbol of +20. This is repeated every 5 cm of trace.
14.
  - a. When the system detects that both ultrasound transducers are picking up the same heart rate, a '?' is printed above the FHR trace.
  - b. Reposition the transducer to pick up two different signals.
  - c. True.
15.
  - a. Connect the transducer to the socket. Place the transducer for optimal pick-up of uterine activity. Between contractions press the Toco baseline key. Note the displayed and recorded value of 20.
  - b. The trace will display 'Toco ext' to indicate an external Toco transducer is in use.
16.
  - a. The catheter should be inserted and connected according to the manufacturers instructions. Zero the monitor by pressing the Toco baseline key.
  - b. Zero.
17.
  - a. The key to adjust the clock time is located in the lower left corner.
  - b. The batteries are located in the back of the monitor in a battery pack.
18.
  - a. With the recorder off, press the recorder ON/OFF key for 2 seconds. Adjust the timer to 20 minutes using [ -- ] or [ + ] . The timer will start after 15 seconds.
  - b. The correct choices are: A,C.

(question 19 does not apply to monitors purchased in the USA)
19.
  - a. With the US or DECG transducer connected to the monitor, press the Function key repeatedly until 'AL' is displayed. Use the [ -- ] or [ + ] key to set the fetal alerting to On which is indicated by the green light. Use the Zero key to scroll to the option ' --A' . Use the [ -- ] or [ + ] key to set the value to 160. Press the function screen to return to the normal display.
  - b. During an alarm event, the event marker key is used to acknowledge the FHR alarm.

## Maternal Parameters

20.
  - a. Ensure that the cuff is completely deflated. Place the ARTERIA marking on the cuff over the appropriate artery. Check that the edge of the cuff falls within the white range marked by the arrows (<-->), (on disposable cuffs this is a blue line without arrows). If it does not, use a larger or smaller cuff that fits.
  - b. Apply the cuff to the patient and connect to the interconnect tubing. Insert the interconnect tubing into the NBP socket. Press the NBP key. Press Mode until Auto is shown. Press Repeat until 15 is displayed. Press Start.
  - c. No other maternal pulse or heart rate source is present and the symbol is a blood pressure cuff.
  - d. A,B,C,D.
21. Press NBP. Press Alarm. Press the Alarm softkey until ON Systolic is displayed. Using the softkeys for L. Limit and H. Limit, then the up/down arrow keys, set the values for a Systolic high to 180 and the Systolic low to 90.
22.
  - a. The monitor will rapidly and repeatedly take the blood pressure for five minutes.
  - b. True
23.
  - a. Place the electrodes on the right and left lower ribs.
  - b. Place right arm (RA) electrode directly below the clavicle and near the right shoulder. Place the left leg (LL) electrode in left lower abdomen.
  - c. Press the maternal heart rate key. Press the softkey for Wave. The waveform is now displayed. With the recorder on, press Freeze, then Print to record a snapshot of the ECG trace.
24.
  - a. Place the sensor with the red light over the nail bed. Connect the cable to the SpO<sub>2</sub> socket. The value will be displayed.
  - b. A icon of a pleth wave.
  - c. Five Minutes; 2.5 minutes.
  - d. Any of the following are limitations to obtaining an accurate SpO<sub>2</sub>: SpO<sub>2</sub> sensor is on the same limb as the NBP connect cuff, improperly placed sensor, venous pulsations, dye dilution chemicals or other dysfunctional hemogloblins, shock, hypothermia, use of vasoactive drugs.

## Fetal SpO<sub>2</sub>

25.
  - A. Alarm status indicator: when the crossed bell is lit the alarms are off.
  - B. Signal Quality indicator lights: reflects the strength of the signal being received by the monitor.
  - C. Pulse indicator: lights in conjunction with the fetal pulse rate when pulsatile activity is of acceptable quality.
  - D. Value display window: FSpO<sub>2</sub> value is displayed and occasionally status indicator symbols. Refer to the FSpO<sub>2</sub> troubleshooting section of the Instructions for Use for the definition of the status indicator displayed in this picture.
26. A and C.

## Fetal Telemetry

27. Transmitter, receiver.
28. Any two of these situations: transmitter is off, transmitter is out of receiver range, transmitter and receiver do not have matching serial numbers and channel frequency numbers, transmitter batteries are dead or transmitter is defective.
29. An interface cable.
30. The steps are:
  - \_6\_ connect the transducer cables and turn on transmitter.
  - \_3\_ connect the interface cable between the receiver and the fetal monitor.
  - \_4\_ switch on the receiver.
  - \_5\_ remove transducer cables from the fetal monitor then turn it ON.
  - \_2\_ insert the battery into the transmitter.
  - \_1\_ check that transmitter and receiver numbers match.



## A

### Accessories

- optional, 164
- standard, 163

### Acknowledging a warning message, 107

### Acknowledging an alarm, 106

### ACOG technical bulletin, 35

### After monitoring, 37

### Alarm limits

- power on screen, 104

### Alarms

- acknowledging, 106
- changing, 107
- changing SpO<sub>2</sub>oximetry limit, 134
- current values, 106
- FSpO<sub>2</sub>, 77
- maternal, 106
- maternal heart rate, 128
- maternal SpO<sub>2</sub> pulse rate, 135
- maternal SpO<sub>2</sub>oximetry level, 134
- MHR, 129
- MHR limits, 130
- NIBP, 115
- recognizing, 106
- restoring default limits, 107
- reviewing all settings, 106
- setting, 107

### Arrhythmia logic

- changing setting, 59
- what is it?, 60

### Artefact as fetal movement, 43

### Average pulse rate, 115

## B

### Barcode

- deleting an entry, 94
- recording a note, 93

### Barcode reader

- switching FMP on and off, 43
- twins offset, 66

### Baselines

- separating, 65

### Batteries

- replacing, 156

### Belt

- cleaning, 148
- fastening, 21
- fixing button, 21
- fixing patient module to, 23
- fixing transducer to, 22

## C

### Calibration check, 140

### Cardio 1/Combi socket

- connecting a transducer, 23

### Cardio 2 socket

- connecting a transducer, 23

### Caring for your monitor, 141

### CCV+, 76

### Cleaning

- belts, 148
- IUP, 147
- IUP transducer adapter cable, 147
- maternal SpO<sub>2</sub> transducers, 148
- monitor, 141
- NIBP cuff, 148
- patient modules, 142
- transducers, 142

### Cleaning agents

- recommended, 143

### Connecting power, 29

### Connecting transducers, 23

### Contrast control, 108

### Cross-channel

- verification, 125
- twins, 63

### Cross-channel verification plus, 76

## D

### Date

- setting, 34, 35

### DECG

- attaching the electrode, 49
- contraindications, 47
- electrodes, 168
- input specifications, 178
- troubleshooting, 61

### DECG adapter cable, 53

### DECG leg plate adapter cable, 56

### DECG legplate transducer using the SafeConnect system, 53

### DECG monitoring

- traditional open-wire method, 50

### DECG patient module

- using the SafeConnect system, 56
- using the traditional method, 51

### Defibrillation, 9

### Disinfecting monitoring equipment, 145

### Display specification, 178

### Disposal, 140

### Domes, types of, 170

## E

### **ECG patient module**

monitoring MECCG, 125

### **Electromagnetic compatibility, 7**

### **Electrical safety check, 140**

### **Electrical surgery, 9**

### **Environment, 6**

### **Error messages, 160**

### **ESU, 9**

### **Event marker**

key, 27

marking artifact or movement, 43

remote, 27

### **Event marker key, 27**

### **Example trace, 26**

### **External devices**

connecting to your monitor, 83

troubleshooting, 90

## F

### **Fetal demise, suspected, 20**

### **Fetal movement**

detecting, 42

FMP, 42

twins, 43

### **FHR**

monitoring twins, 63

monitoring using ultrasound, 39

questionable, 62

troubleshooting, 45

### **FMP**

activity blocks, 42

and M1310A fetal telemetry, 43

and twins, 43

artifact, 43

barcode reader, 43

remote event marking, 43

statistics, 42

switching on and off, 43

### **FSpO<sub>2</sub>**

alarm criteria, 77

applying the sensor, 74

changing alarm limits, 78

inaccurate measurements, 81

inop alarm, 79

introduction, 73

pulse indicator, 75

pulse search symbol, 74

pulse signal loss, 81

saturation alarm, 77

saturation value, 77

sensor lifted symbol, 74

Sensor light emitter, 74

signal quality indicator, 75, 76

time delay alarm, 77

troubleshooting, 80

turning alarm on or off, 78

### **FSpO<sub>2</sub>2**

Sensor Placement Guide, 73

### **Fuses, replacing, 157**

## G

### **Gel types, 166**

### **Grounding cable, 4, 30**

### **Guide overview, 11**

## I

### **Input channels**

at a glance, 25

overview, 13

### **Input specifications, 178**

### **Intrauterine pressure. See**

#### **IUP**

#### **IUP**

connecting transducer to monitor, 70

monitoring, 70

### **IUP transducer**

testing, 155

### **IUP transducer adapter**

#### **cable**

cleaning, 147

## L

### **Lead position for maternal**

#### **ECG, 123**

### **Leakage current, 10**

## M

### **Maintenance**

calibration check, 140

mechanical inspection, 140

preventive, 139

routine inspection, 139

visual inspection, 139

### **Marking an event, 27**

### **Marking an event. See Event marker**

### **Maternal alarms, 106**

### **Maternal ECG**

alarm, 128

applying electrodes, 123

changing the waveform speed, 127

freezing the waveform, 127

printing the waveform, 127

See MECCG

starting monitoring, 121

waveform, 126

### **Maternal heart rate**

alarm limits, 130

measurement problems, 131

MECCG alarm, 128

recording from external device, 83

turning alarms on and off, 129

### **Maternal main screen, 104**

returning to, 106  
**Maternal parameters, overview,** 15  
**Maternal SpO<sub>2</sub>**  
changing the alarm limit, 134  
cleaning the transducer, 148  
measurement limitations, 136  
pulse rate alarm, 135  
recording from external device, 83  
troubleshooting, 135  
turning alarms on and off, 134  
warning messages, 135  
**Maternal temperature**  
recording from external device, 83  
**Maximum input/output voltages,** 3  
**MECG**  
alarms, 128  
displaying the waveform, 126  
electrodes, 167  
freezing the waveform, 127  
heartrate icon, 127, 128  
printing the waveform, 127  
waveform, 123  
waveform speed, 127  
**Midwives,** 11  
**Monitor**  
cleaning, 141  
disposal of, 140  
overview, 11  
power off, 107  
switching off, 37  
**MRI,** 9  
  
**N**  
  
**NIBP**

alarm, 115  
alarm setup, 112  
alarms, 115  
automatic mode, 113  
average pulse rate, 115  
calibration check, 140  
cancelling a measurement, 114  
changing alarms, 117  
changing measurement mode, 114  
changing modes, 114  
manual mode, 113  
measurement limitations, 120  
pulse rate icon, 128  
recording, 118  
recording from external device, 83  
selecting a measuring mode, 112  
setup screen, 112  
starting a measurement, 112  
starting monitoring, 111  
stat mode, 113  
troubleshooting, 118  
turning alarms on and off, 116  
warning messages, 118  
**Non stress test**  
See NST  
**Non-invasive blood pressure**  
See NIBP  
**NST**  
setting the timer, 99  
  
**O**  
  
**Optional accessories,** 164  
  
**P**  
  
**Paper**

correct type, 33  
removing, 33  
tearing off a trace, 37  
types, 166  
**paper**  
storing, 148  
**Paper speed,** 35  
changing, 35  
default, 35  
setting, 35, 36  
**Parameter test,** 152  
**Parts and keys,** 12  
**Patient modules**  
connecting to monitor, 23  
fixing to belt, 23  
**Patient safety,** 1  
**Power**  
alarm values on restoration of, 107  
failure, 107  
restoring, 107  
**Power on screen**  
alarm limits, 104  
**Protective earth,** 5  
**Pulse icon,** 133  
**Pulse rate**  
from NIBP measurement, 115  
  
**Q**  
  
**Questionable fetal heart rate,** 62  
**Quick test,** 151  
  
**R**  
  
**Recognizing an alarm,** 106  
**Recorder**  
keys, 17  
specifications, 179  
**recorder**  
paper storage, 148

**Recording a note**, 93  
**Redux creme**, 50  
**Remote event marker**, 27  
**Remote event marker key**, 27  
**Replacing batteries**, 156  
**Replacing fuses**, 157  
**Reset**, 103  
**Reset key**, 103  
acknowledging a warning message, 107  
**Restoring default alarm limits**, 107  
**Reviewing alarm settings**, 106

**S**

**Self test**, 180  
**Separating twin traces**, 65  
**Setting keys**, 18  
**Setting the date**, 35  
**Setting the time**, 35  
**Signal quality**, 24  
**Signal quality lamp**  
connecting a transducer, 23  
**Softkeys**, 103  
**specifications**  
display, 178  
inputs, 178  
recorder, 179  
**Spillage**, 7  
**Spiral electrode**  
attaching, 49  
**SpO<sub>2</sub>**  
See Maternal SpO<sub>2</sub> or Fetal SpO<sub>2</sub>  
**Standard 5-lead ECG**, 123  
**Suspected fetal demise**, 20  
**Switching off the monitor**, 37  
**Switching on the monitor**, 30

**Switching on the recorder**, 33

## T

### Testing

IUP transducer, 155  
quick test, 151  
self test, 180

**Time, setting**, 35

### Toco

baseline, 23  
baseline key, 70  
connecting a transducer, 23  
external monitoring, 69  
interuterine monitoring, 70  
testing a transducer, 154  
troubleshooting, 71  
zeroing the monitor, 70

**Trace example**, 26

### Transducer Knob

**Adapter**, 22

**Transducer knob adapter**, 172

**Transducer testing**, 154

Toco, 154  
ultrasound, 154

**Transducer/patient module combinations**, 25

### Transducers

accessories, 167  
cleaning, 142  
connecting, 23  
connecting to monitor, 23  
fixing to belt, 22  
immersion, 39  
maternal SpO<sub>2</sub>, 148  
testing, 154, 155

### Troubleshooting

DECG, 61  
FSpO<sub>2</sub>, 80

maternal heart rate measurement problems, 131  
Maternal SpO<sub>2</sub>, 135, 136  
NIBP, 118  
noninvasive blood pressure, 118  
Toco, 71  
twins monitoring, 67  
ultrasound, 45

## Twins

and FMP, 43  
cross channel verification, 63  
difference in heart rate traces, 63  
invasive monitoring, 64  
monitoring FHR, 63  
non-invasive monitoring, 64  
offsetting baselines, 65  
separating traces, 65  
troubleshooting, 67  
**Twins offset**, 65  
understanding the trace, 66

## U

### Ultrasound

applying gel, 41  
monitoring FHR, 39  
testing a transducer, 154  
trace delay, 39  
troubleshooting, 45

**Understanding the trace**, 26

### Uterine activity

monitoring, 69, 70  
troubleshooting, 71

## V

**Voltage setting**, 29

**Volume control**, 108



## W

### **Warning message**

acknowledging, 107

### **Warning messages**

acknowledging, 107

maternal SpO<sub>2</sub>, 135

NIBP, 118

### **Waveform**

changing speed, 127

freezing, 127

maternal ECG, 126

printing, 127

## Z

### **Zeroing the monitor**

See Toco